



Totally Focused. Totally Independent.

Technical Guide

ECP32 4 C
C-TYPE



The world's largest
independent producer of
alternators 1 – 5,000kVA

Standards

Alternators are designed and produced within an ISO 9001 environment. The entire series is manufactured according to, and complies with, the most common specifications such as CEI 2-3, IEC 34-1, EN 60034-1, VDE 0530, BS 4999-5000, NF 51.111, CAN/CSA-C22.2 No14-95-No100-95, NEMA MG 1-2011, ISO 8528-3. Other standards such as UL1446, UL 1004/4 and /B are available on request.

Windings and Performances

All windings are 2/3rds pitch to eliminate triplen harmonics within the voltage waveform and to avoid excessive neutral currents in certain parallel operating conditions. A fully interconnected aluminium or copper damper cage is supplied on the rotor of all models (excluding the ECP3 series).

- ▶ 12 wire reconnectable:
 - 50Hz – 380V to 440V and 220/110V to 240/120V (de-rates may apply at certain voltages)
 - 60Hz – 380V to 480V and 220/110V to 240/120V (de-rates may apply at certain voltages)
- ▶ 6 wire reconnectable:
 - 50Hz – 380V to 440V and 220V to 240V (de-rates may apply at certain voltages)
 - 60Hz – 380V to 480V and 220V to 240V (de-rates may apply at certain voltages)

Winding Configurations	Standard		Special (dedicated)			
	12 wire Reconnectable	6 wire Reconnectable	380V and 600V 60Hz	690V 50/60Hz	220-240V 1ph 50Hz	220-240V 1ph 60Hz
ECP3 to ECO38	Std	Option	Option	Option	Option	Option
ECO40 to ECO46	Std	Option	Option	Option	Option (to ECO40)	Option (to ECO40)
Insulation materials	Class H	Class H	Class H	Class H	Class H	Class H
High efficiency	Std	Std	Std	Std	Std	Std
High motor starting	>300%	>300%	>300%	>300%	>300%	>300%
THD (Total Harmonic Distortion)	Typically <3.5% full load L-L	Typically <3.0% full load L-L	Typically <3.5% full load L-L	Typically <3.5% full load L-L	Typically <4.5% full load L-N	Typically <4.5% full load L-N
Interference suppression	VDE 0875 G/N/K, EN61000-6-3, EN61000-6-2, others available on request					

Winding Protection

There are various degrees of protection for the windings following the standard impregnation process, as can be seen here. The TOTAL+ butadienic black flexible coating is recommended for arduous applications.

Winding Protection:	STANDARD	STANDARD+	GREY	GREY+	TOTAL+ (3% de-rate may apply on certain models)
ECP3	Std	Option	Option	Option	Option
ECP28 and ECP32	-	Std	Option	Option	Option
NPE32, ECP34 to ECO46	-	-	Std	Option	Option

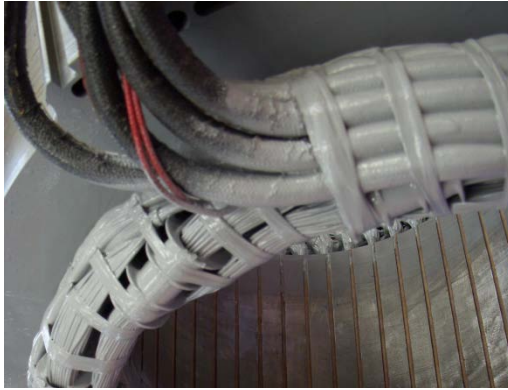

Grey treatment (marinization) on the left, TOTAL+ treatment shown on the right. The EG43 grey varnish, is an high temperature insulating enamel that forms a tough and flexible film, with excellent moisture and chemical protection. It is water and oil proof, and also protects windings from abrasion. It is applied spraying an over coating layer over the impregnated winding, or dipping the stator in a varnish barrel for superior treatments

The TOTAL+ is a protection system that makes Mecc Alte special. It is the ultimate winding treatment that offers truly superior performances when the environment is really harsh, or the application very demanding. It is a rubbery protection treatment, used to replace epoxies and silicones winding encapsulation. The TOTAL+ flexible black compound cures to a tough, resilient, glossy black thick coating that seals the copper against moisture and chemical attacks. Due to its encapsulation capability and flexibility, is also extremely resistant to the particle abrasion as it adsorbs the impacts. Moreover, the high flexibility leads to a long-trouble less life protection, as the compound follows elastically the thermal expansion cycles of the windings from the cold to the hot condition and vice versa without forming any cracks.

Protection for Environment

In addition to protection on the windings themselves, the alternators can have increased ingress protection. Standard levels are IP23 with further upgrades available to include inlet filters, IP43 and IP45: 7% de-rates apply on inlet filters and IP43 protection. 20-30% de-rates apply for IP45 depending on alternator model.

Additional air exit louvres (called IP23+) are optionably retrofittable in the overall ECP32 to ECO 46 range, in order to comply to the most strict marine regulations.



Construction

The robust mechanical structure withstands up to 5G in any direction and 9G vertically and its design permits easy access to the connections and components during routine maintenance check-ups. The mechanical design has used the most advanced FEM techniques. The materials used are: FEPI2 steel for the frame, C45 steel for the shaft and cast iron or aluminum pressure die cast for the end-brackets: fans are aluminum die casted either nylon fiber glass loaded, UL compliant materials. Rotors are dynamically balanced according grade 2.5 of ISO 1940-1.

Terminals and Terminal Box

Easy access to regulators is assured through a pull out drawer or a drop down panel to allow safer adjustment. Large terminal boxes allow easy access of power cables, in the ECO43 and ECO46 higher power ranges the terminal allow the convenient choice of power cable or busbar connection with versatility of entry and connection. Current transformers are available as an option on series ECO 40, 43 and 46 with single or dual output.

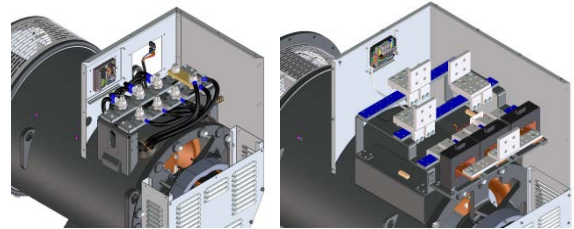

Excitation and Regulation Systems

All ECP/ECO series have MAUX auxiliary winding to power the digital regulator. Both DSR and the DER1 are available to connect to PC through the DxR2 USB interface and DxR TERMINAL software to interrogate/download alarms & settings for analysis or for cloning other regulators. DER2 has got an integrated USB connection and can be connected to the PC without any optional connection boards. More settings such as LAMS, digital RAM based synchronous external control and soft start are obtainable through the DxR connection. Simple analogue potentiometers are available for the more usual adjustments.

Excitation Systems	DSR	DER1	DER2
ECP3 to ECO38	Std	Option	Option
ECO40 to ECO46	-	Std	Option
Parallel Operation	√	√	√
Mains Parallel	√	√	√
3 Phase Sensing (rms)	-	√	√
Accuracy	+/-1%	+/-0.5%	+/-0.5%
Remote Voltage Control	√	√	√
Alarm Log	√	√	√
Analogue and Digital Configurable	√	√	√
LAMS (Load Acceptance V/f)	√	√	√
APO (Active Protection Output)	√	√	√
Soft Start	√	√	√
High dynamic response	-	-	√
USB connection without external boards	-	-	√

For a given motor start duty a smaller machine may be selected – also enhanced by low sub-transient reactance values for non-linear loads. The whole range from 6.5 to 3400kVA is capable of >300% sustained short circuit current for up to 20 seconds.

Optional PMG3

PMG3 can be retro fit or factory fit on ECO 40, 43 and 46 series. This smart MeccAlte design allows an easy fix kit, through a tapered cone coupling and a simple replacement of the rear air louvre. PMG3 is also available on ECO 38, when ordered from the factory.

The complete AVR range is fully compatible with both MAUX and PMG3 systems, this minimises spare part management and flexibility of stock as one AVR suits all applications. The PMG3 is delivering the same amount of kVA available with the MAUX.

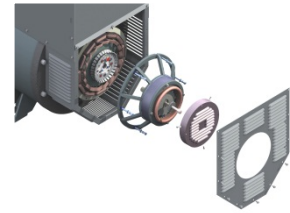

Accessories

Additional optionals can be fit on our alternator series, such as PTC thermistors or PT100 both on windings and bearings, space heaters, high and low profile of terminal boxes (on most series), air filter clogging sensors, rotating diode bridge failure sensor (RBD), power factor controller for parallel operation (PFR/2), parallel devices (standard from ECO 40), air filters, IP43 and IP45 protections, marine IP23 + protection for SOLAS requirements and many others.

Deration coefficients

Altitude (meters)	Ambient temperature (Celsius)					
	25	40	45	50	55	60
≤ 1000	1.07	1	0.96	0.93	0.91	0.89
$> 1000 \leq 1500$	1.01	0.96	0.92	0.89	0.87	0.84
$> 1500 \leq 2000$	0.96	0.91	0.87	0.84	0.83	0.79
$> 2000 \leq 3000$	0.9	0.85	0.81	0.78	0.76	0.73

Notes on short circuit curves

The indicated coefficients have to be used to correct the three phase short circuit curves values as a function of the rated voltage.

The indicated coefficient have to be used to correct the three phase short circuit curves values as a function of the type of short circuit voltage.

50 Hz		60 Hz	
Voltage	Factor	Voltage	Factor
380	0.93X	415	0.85X
400	1X	440	0.90X
415	1.04X	460	0.95X
440	1.10X	480	1X

	3 phase	2 phase L-L	1 phase L-N
<i>Istantaneous</i>	1X	0.87X	1.30X
<i>Minimum</i>	1X	1.80X	3.20X
<i>Sustained</i>	1X	1.50X	2.50X
<i>Max Duration</i>	20 sec.	10 sec.	4 sec.

All the curves are shown for series or parallel star connection at 400V 50 Hz or 480V 60 Hz. If the unit is reconnected from series to parallel star, the additional coefficient is 2X. From series star to series delta, it is 1.72X. From series star to parallel delta, it is 3.44X.

General characteristics

Pole number	4	Insulation class	H
Phase number	3	Protection class	IP23
Number of wires	12	NDE Bearing type	6309-2RS
Execution	Brushless	DE Bearing type	6312-2RS
Regulator type	DSR	Maximum Overspeed	2250
Winding pitch	2/3	Altitude	0-1000
Code voltage reference	T0405S3	Balancing	ISO1940-1

Ratings 50Hz

kVA / kW @ Temp. Rise / Ambient °C - 0.8 PF

	STANDBY-163/27				STANDBY-150/40				H-125/40				F-105/40				B-80/40				
Series	380V	400V	415V	440V	380V	400V	415V	440V	380V	400V	415V	440V	380V	400V	415V	440V	380V	400V	415V	440V	
Parallel Star YY	190V	200V	208V	220V	190V	200V	208V	220V	190V	200V	208V	220V	190V	200V	208V	220V	190V	200V	208V	220V	
Series Delta Δ	220V	230V	240V	254V	220V	230V	240V	254V	220V	230V	240V	254V	220V	230V	240V	254V	220V	230V	240V	254V	
Parallel Delta ΔΔ	110V	115V	120V	127V	110V	115V	120V	127V	110V	115V	120V	127V	110V	115V	120V	127V	110V	115V	120V	127V	
ECP32 1S4 C	kVA	41	41	41	33	39	39	39	31,6	37,5	37,5	37,5	30	35	35	35	28	30	30	30	24
	kW	32,8	32,8	32,8	26,4	31,2	31,2	31,2	25,3	30	30	30	24	28	28	28	22,4	24	24	24	19,2
ECP32 2S4 C	kVA	49,5	49,5	46	37,5	48,7	48,7	45	36	45	45	42	34	41	41	39	33	36	36	34	27
	kW	39,6	39,6	36,8	30	39,0	39,0	36	28,8	36	36	33,6	27,2	32,8	32,8	31,2	26,4	28,8	28,8	27,2	21,6
ECP32 1M4 C	kVA	55	55	55	44	52,5	52,5	52,5	42	50	50	50	40	48	48	48	38	40	40	40	32
	kW	44	44	44	35,2	42	42	42	33,6	40	40	40	32	38,4	38,4	38,4	30,4	32	32	32	25,6
ECP32 2M4 C	kVA	68,8	68,8	68,8	52	65	65	65	49,5	62,5	62,5	62,5	47,5	59,5	59,5	59,5	42,6	50	50	50	38
	kW	55,0	55,0	55,0	41,6	52	52	52	39,6	50	50	50	38	47,6	47,6	47,6	34,1	40	40	40	30,4
ECP32 1L4 C	kVA	82,5	82,5	82,5	77	78	78	78	73	75	75	75	70	67	67	67	62	60	60	60	56
	kW	66	66	66	61,6	62,4	62,4	62,4	58,4	60	60	60	56	53,6	53,6	53,6	49,6	48	48	48	44,8
ECP32 2L4 C	kVA	91	91	91	85	85	85	85	79	82,5	82,5	82,5	77	73,2	73,2	73,2	68	66	66	66	62
	kW	72,8	72,8	72,8	68	68	68	68	63,2	66	66	66	61,6	58,6	58,6	58,6	54,4	52,8	52,8	52,8	49,6

Ratings 60Hz

kVA / kW @ Temp. Rise / Ambient °C - 0.8 PF

	STANDBY-163/27				STANDBY-150/40				H-125/40				F-105/40				B-80/40				
Series	415V	440V	460V	480V	415V	440V	460V	480V	415V	440V	460V	480V	415V	440V	460V	480V	415V	440V	460V	480V	
Parallel Star YY	208V	220V	230V	240V	208V	220V	230V	240V	208V	220V	230V	240V	208V	220V	230V	240V	208V	220V	230V	240V	
Series Delta Δ	240V	254V	265V	277V	240V	254V	265V	277V	240V	254V	265V	277V	240V	254V	265V	277V	240V	254V	265V	277V	
Parallel Delta ΔΔ	120V	127V	133V	138V	120V	127V	133V	138V	120V	127V	133V	138V	120V	127V	133V	138V	120V	127V	133V	138V	
ECP32 1S4 C	kVA	43,5	47	49,5	49,5	42	45	47	47	39,5	43	45	45	37	41	43	43	31,6	34,4	36	36
	kW	34,8	37,6	39,6	39,6	33,6	36	37,6	37,6	31,6	34,4	36	36	29,6	32,8	34,4	34,4	25,3	27,5	28,8	28,8
ECP32 2S4 C	kVA	52	55	59	59	50	53	57	57	47	50	54	54	43	48	52	52	37,6	40	43,2	43,2
	kW	41,6	44	47,2	47,2	40	42,4	45,6	45,6	37,6	40	43,2	43,2	34,4	38,4	41,6	41,6	30,1	32	34,6	34,6
ECP32 1M4 C	kVA	60,5	66	66	66	58	63	63	63	55	60	60	60	53	58	58	58	44	48	48	48
	kW	48,4	52,8	52,8	52,8	46,4	50,4	50,4	50,4	44	48	48	48	42,4	46,4	46,4	46,4	35,2	38,4	38,4	38,4
ECP32 2M4 C	kVA	76	80	82,5	82,5	71	75	77,5	77,5	69	73	75	75	63	70	71,5	71,5	55,2	58	60	60
	kW	60,8	64	66	66	56,8	60	62	62	55,2	58	60	60	50,4	56	57,2	57,2	44,2	46	48	48
ECP32 1L4 C	kVA	86	90	96	99	81	86	91	93,7	78	82	87	90	73	80	83	83	62,4	65,6	69,6	72
	kW	68,8	72	76,8	79,2	64,8	68,8	72,8	75,0	62,4	65,6	69,6	72	58,4	64	66,4	66,4	49,9	52,5	55,7	57,6
ECP32 2L4 C	kVA	97	106	110	110	90	98	102	102	88	96	100	100	81	89	92	92	70,4	76,8	80	80
	kW	77,6	84,8	88	88	72	78,4	81,6	81,6	70,4	76,8	80	80	64,8	71,2	73,6	73,6	56,3	61,4	64	64

Reactance & Time constants- Class H / 400V

Unsaturated (ref. EN60034-4)			ECP32 1S4 C	ECP32 2S4 C	ECP32 1M4 C	ECP32 2M4 C	ECP32 1L4 C	ECP32 2L4 C
X_d	Direct-axis synchronous reactance	%	316,7	339,3	316,3	276,3	368,2	376
X'_d	Direct-axis transient reactance	%	15,6	15,9	14,8	13,8	17,3	16,8
X''_d	Direct-axis subtransient reactance	%	11	11,9	8,7	8,1	10,1	8,7
X_q	Quadrature-axis synchronous reactance	%	101,7	110,5	123	113,9	142,9	147,9
X'_q	Quadrature-axis transient reactance	%	101,7	110,5	123	113,9	142,9	147,9
X''_q	Quadrature-axis subtransient reactance	%	33,7	34	34,9	33,8	42,2	43,1
X₂	Negative-sequence reactance	%	21,8	22,4	21,2	20,4	25,6	25,3
X₀	Zero sequence reactance	%	2,89	3,04	3,33	3,21	4,39	4,11
Saturated								
X_d	Direct-axis synchronous reactance	%	269,2	288,4	268,9	234,9	313	319,6
X'_d	Direct-axis transient reactance	%	13,3	13,5	12,6	11,7	14,7	14,3
X''_d	Direct-axis subtransient reactance	%	9,35	10,1	7,4	6,88	8,58	7,4
X_q	Quadrature-axis synchronous reactance	%	86,4	93,9	104,6	96,8	121,5	125,7
X'_q	Quadrature-axis transient reactance	%	86,4	93,9	104,6	96,8	121,5	125,7
X''_q	Quadrature-axis subtransient reactance	%	28,6	28,9	29,7	28,7	35,9	36,6
X₂	Negative-sequence reactance	%	18,5	19	18	17,3	21,8	21,5
X₀	Zero sequence reactance	%	2,89	3,04	3,33	3,21	4,39	4,11
K_{cc}	Short circuit ratio		0,37	0,35	0,37	0,43	0,32	0,31
T'_d	Transient time constant	sec	0,056	0,059	0,062	0,055	0,081	0,074
T''_d	Subtransient time constant	sec	0,012	0,014	0,014	0,011	0,016	0,016
T'_{do}	Open circuit time constant	sec	1,14	1,26	1,31	1,1	1,73	1,67
T_a	Armature time constant	sec	0,013	0,016	0,018	0,016	0,022	0,022

Additional information - Class H / 400V

I_o	Excitation current at no load	A	0,6	0,8	0,7	0,7	0,6	0,5
I_c	Excitation current at full load	A	2,7	2,8	2,5	2,6	2,4	2,4
Overload			1 hour in a 6 hours period 110% rated load					
Overload per 20 sec.		%	300					
Heat dissipation		W	4247	5096	5300	5928	6741	7333
Telephone Harmonic Factor - THF		%	<2	<2	<2	<2	<2	<2
Waveform Distors.(THD) full load LL/LN		%	2,8 / 2,8	1,9 / 2	1,8 / 1,9	2,1 / 2,1	2,2 / 2,2	2,9 / 2,9
Waveform Distors.(THD) no load LL/LN		%	3 / 3,1	2,7 / 2,6	2,6 / 2,6	2,7 / 2,7	2,9 / 2,9	2,5 / 2,5

Reactance & Time constants- Class H / 480V

Unsaturated (ref. EN60034-4)			ECP32 1S4 C	ECP32 2S4 C	ECP32 1M4 C	ECP32 2M4 C	ECP32 1L4 C	ECP32 2L4 C
X_d	Direct-axis synchronous reactance	%	316,7	339,3	316,3	276,3	368,2	379,8
X'_d	Direct-axis transient reactance	%	15,6	15,9	14,8	13,8	17,3	17
X''_d	Direct-axis subtransient reactance	%	11	11,9	8,7	8,1	10,1	8,79
X_q	Quadrature-axis synchronous reactance	%	101,7	110,5	123	113,9	142,9	149,4
X'_q	Quadrature-axis transient reactance	%	101,7	110,5	123	113,9	142,9	149,4
X''_q	Quadrature-axis subtransient reactance	%	33,7	34	34,9	33,8	42,2	43,5
X₂	Negative-sequence reactance	%	21,8	22,4	21,2	20,4	25,6	25,6
X₀	Zero sequence reactance	%	2,89	3,04	3,33	3,21	4,39	4,15
Saturated								
X_d	Direct-axis synchronous reactance	%	269,2	288,4	268,9	234,9	313	322,8
X'_d	Direct-axis transient reactance	%	13,3	13,5	12,6	11,7	14,7	14,4
X''_d	Direct-axis subtransient reactance	%	9,35	10,1	7,4	6,88	8,58	7,47
X_q	Quadrature-axis synchronous reactance	%	86,4	93,9	104,6	96,8	121,5	127
X'_q	Quadrature-axis transient reactance	%	86,4	93,9	104,6	96,8	121,5	127
X''_q	Quadrature-axis subtransient reactance	%	28,6	28,9	29,7	28,7	35,9	37
X₂	Negative-sequence reactance	%	18,5	19	18	17,3	21,8	21,8
X₀	Zero sequence reactance	%	2,89	3,04	3,33	3,21	4,39	4,15
K_{cc}	Short circuit ratio		0,37	0,35	0,37	0,43	0,32	0,31
T'_d	Transient time constant	sec	0,056	0,059	0,062	0,055	0,081	0,074
T''_d	Subtransient time constant	sec	0,012	0,014	0,014	0,011	0,016	0,016
T'_{do}	Open circuit time constant	sec	1,14	1,26	1,31	1,1	1,73	1,67
T_a	Armature time constant	sec	0,013	0,016	0,018	0,016	0,022	0,022

Additional information - Class H / 480V

I_o	Excitation current at no load	A	0,6	0,8	0,7	0,7	0,6	0,5
I_c	Excitation current at full load	A	2,7	2,8	2,5	2,6	2,4	2,4
Overload			1 hour in a 6 hours period 110% rated load					
Overload per 20 sec.		%	300					
Heat dissipation		W	5096	6171	5691	6519	7295	8106
Telephone Interference Factor - TIF			<45	<45	<45	<45	<45	<45
Waveform Distors.(THD) full load LL/LN		%	2,8 / 2,8	1,9 / 2	1,8 / 1,9	2,1 / 2,1	2,2 / 2,2	2,9 / 2,9
Waveform Distors.(THD) no load LL/LN		%	3 / 3,1	2,7 / 2,6	2,6 / 2,6	2,7 / 2,7	2,9 / 2,9	2,5 / 2,5

Efficiencies @ 50Hz

Models		380V 50Hz					400V 50Hz					415V 50Hz					440V 50Hz				
		0.25	0.5	0.75	1	1.1	0.25	0.5	0.75	1	1.1	0.25	0.5	0.75	1	1.1	0.25	0.5	0.75	1	1.1
ECP32 1S4 C	%	85,9	88,9	88,7	87,7	87,2	85,9	89,0	88,7	87,6	87,1	85,7	88,9	88,7	87,4	87,0	85,5	88,9	88,2	86,9	86,4
ECP32 2S4 C	%	85,9	88,9	88,7	87,7	87,2	85,9	89,0	88,7	87,6	87,1	85,7	88,9	88,7	87,4	86,8	85,5	88,9	88,2	86,9	86,4
ECP32 1M4 C	%	89,1	89,5	89,2	88,2	87,8	89,6	89,7	89,5	88,3	87,8	89,3	89,5	89,3	88,0	87,6	88,6	88,9	88,7	87,5	86,9
ECP32 2M4 C	%	90,7	91,5	90,5	89,3	88,8	90,6	91,7	90,7	89,4	88,8	90,3	91,4	90,3	89,2	88,6	89,6	90,6	89,5	88,3	87,7
ECP32 1L4 C	%	91,5	91,6	90,8	89,9	89,4	91,4	91,8	91,0	89,9	89,4	91,2	91,7	90,9	89,6	89,0	90,8	91,6	90,5	89,3	88,7
ECP32 2L4 C	%	91,8	91,9	90,9	89,9	89,4	91,7	92,1	91,2	90,0	89,5	91,3	91,9	91,0	89,6	89,0	91,0	91,9	90,6	89,3	88,7

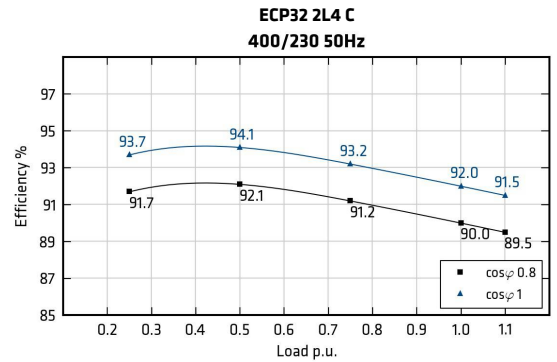
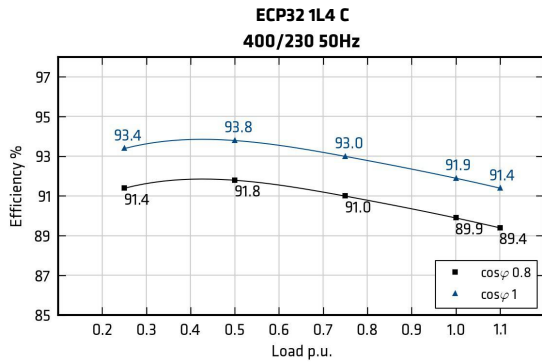
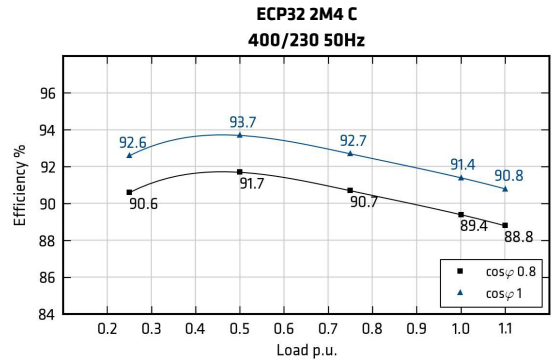
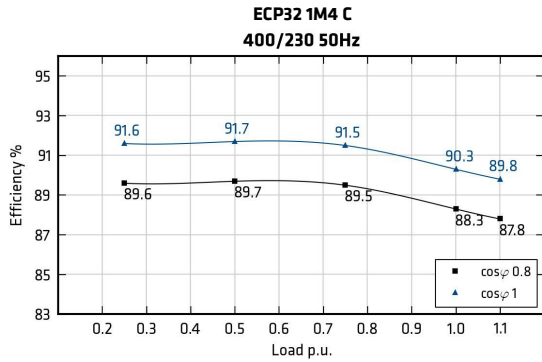
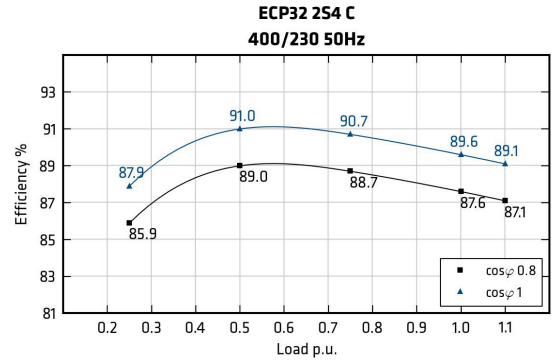
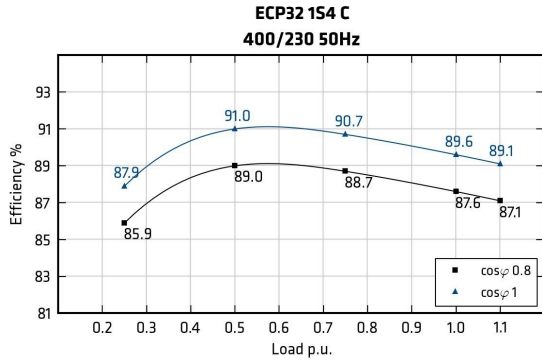

Efficiencies @ 60Hz

Models		415V 60Hz					440V 60Hz					460V 60Hz					480V 60Hz				
		0.25	0.5	0.75	1	1.1	0.25	0.5	0.75	1	1.1	0.25	0.5	0.75	1	1.1	0.25	0.5	0.75	1	1.1
ECP32 1S4 C	%	87,6	89,2	87,8	86,5	86,1	88,4	89,7	88,3	87,0	86,6	88,8	90,2	88,7	87,4	87,1	88,8	90,2	88,7	87,6	87,3
ECP32 2S4 C	%	87,6	89,1	87,7	86,5	86,0	88,4	89,6	88,3	87,1	86,6	88,8	90,1	88,7	87,6	87,1	88,8	90,1	88,7	87,5	87,2
ECP32 1M4 C	%	88,4	89,6	89,6	87,5	86,7	88,5	89,7	89,9	88,9	88,2	88,5	89,9	90,3	89,2	88,6	88,6	90,2	90,5	89,4	88,9
ECP32 2M4 C	%	90,5	91,2	90,5	89,5	89,1	90,9	91,5	90,7	89,7	89,2	91,1	91,6	91,0	90,0	89,5	91,5	92,0	91,3	90,2	89,8
ECP32 1L4 C	%	91,3	91,9	91,1	90,1	89,5	91,4	92,0	91,3	90,5	90,1	91,4	92,1	91,6	90,7	90,2	91,1	92,2	91,8	90,8	90,3
ECP32 2L4 C	%	91,5	92,0	91,2	90,1	89,7	91,5	92,1	91,4	90,5	90,2	91,4	92,1	91,6	90,7	90,4	91,3	92,3	91,8	90,8	90,4

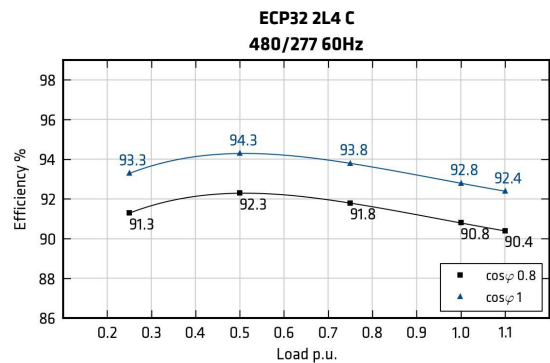
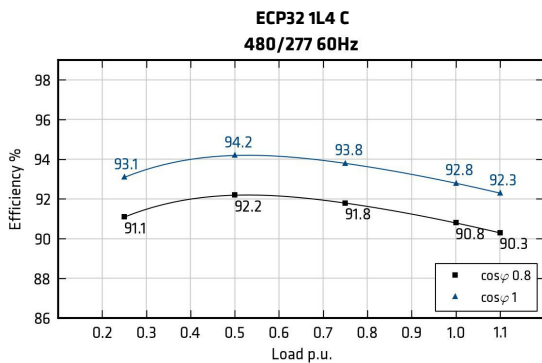
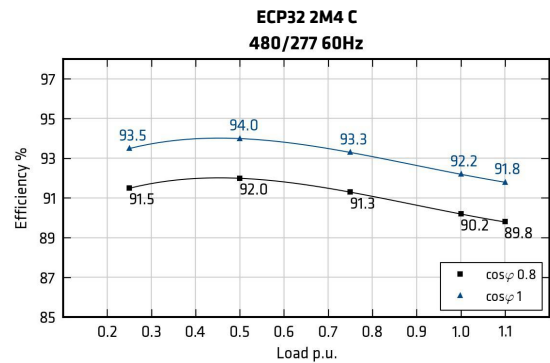
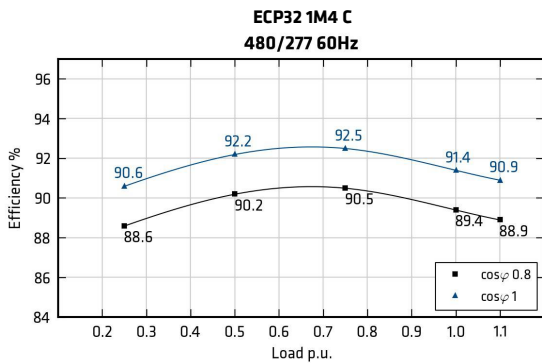
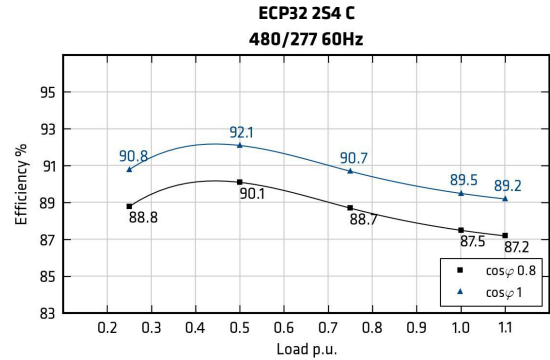
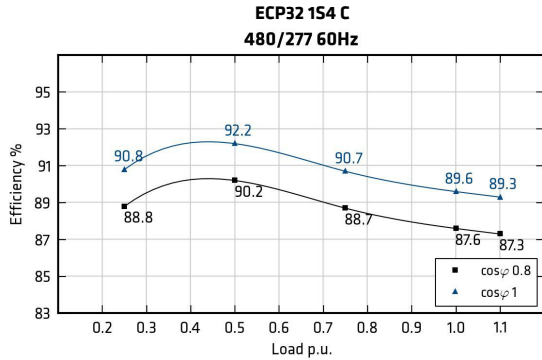

Transients voltage

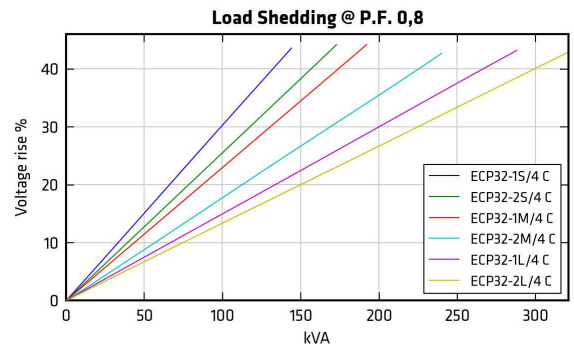
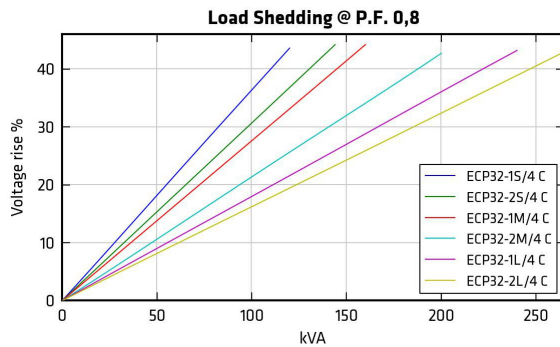
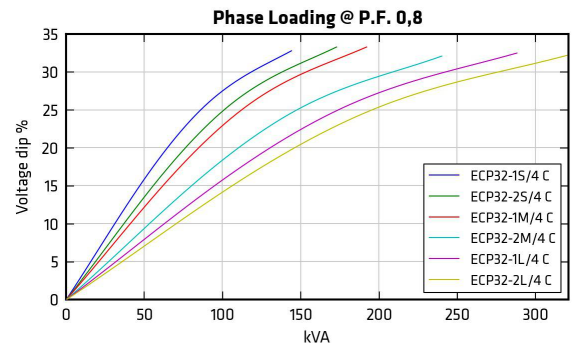
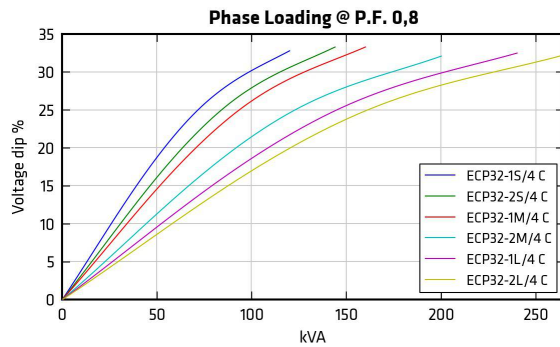
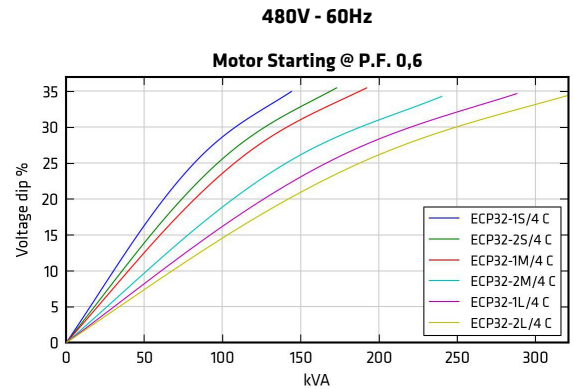
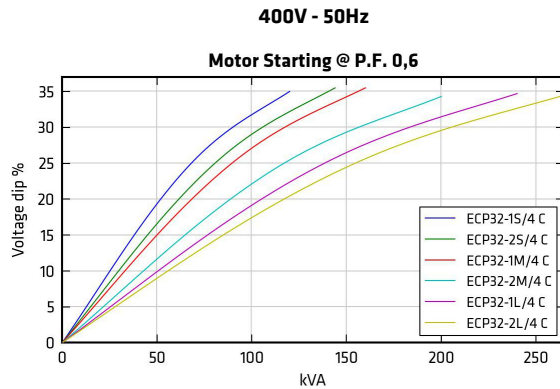

In order to scale transient curves as a function of a power factor or voltage if not indicated, please proceed as follows:

Power Factor coefficient corrector (PFCC), to be used on power factor 0.6 curves:

$$PFCC = \sin(\text{ARCCos}(\text{PF}_{\text{new}})) / 0.8$$

Example. The PFCC at power factor 0.3 is 1.192 [$PFCC = \sin(\text{ARCCos}(0.3)) / 0.8$]. This means that the voltage fall at a given power at pf 0.3 is equivalent to the one that can be read on the pf 0.6 curve if the load is considered 1.192 times bigger (19% higher value.).

In this example, a 100 kVA load insertion at pf 0.3 is equivalent in voltage fall to a 119kVA load insertion at pf 0.6.

Voltage coefficient corrector (VCC):

$$VCC = (400/V_{\text{new}})^2 \text{ if } 50 \text{ Hz}; VCC = (480/V_{\text{new}})^2 \text{ if } 60 \text{ Hz}$$

Example. VCC at 415V 60 Hz is 1.338 [$VCC = (480/415)^2$]. This means that the voltage fall at a given power at 415V is equivalent to the one that can be read on the power factor 0.6 curve if the load is considered 1.338 times bigger (33% higher value.).

In this example, a 100 kVA load insertion at 415V is equivalent in voltage fall to a 133kVA load insertion at 480V.

50Hz Short circuit decrement curves - No load excitation at rated speed

ECP32 1S4 C

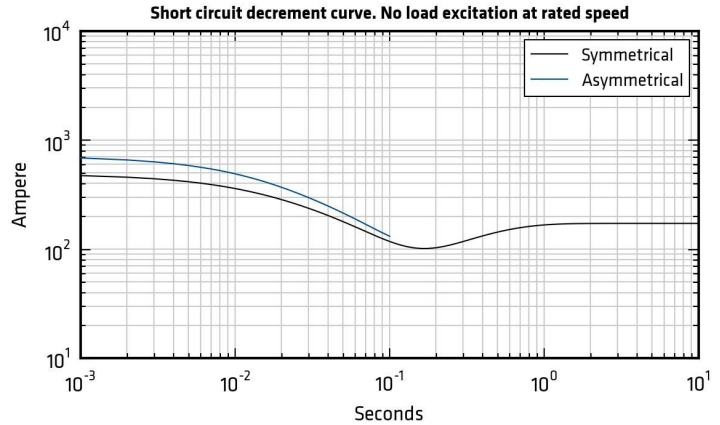

ECP32 2S4 C

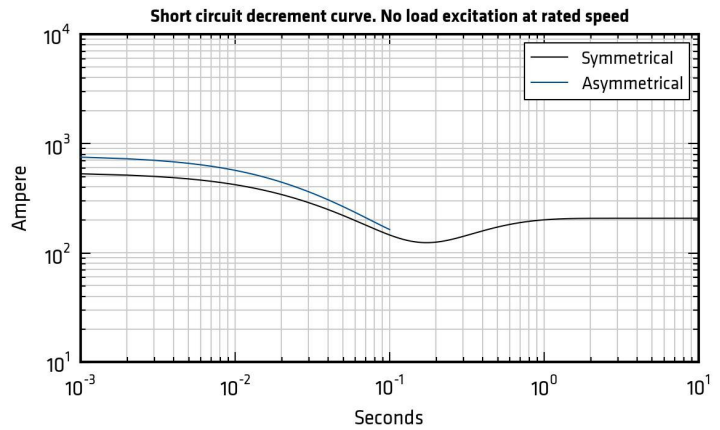

ECP32 1M4 C

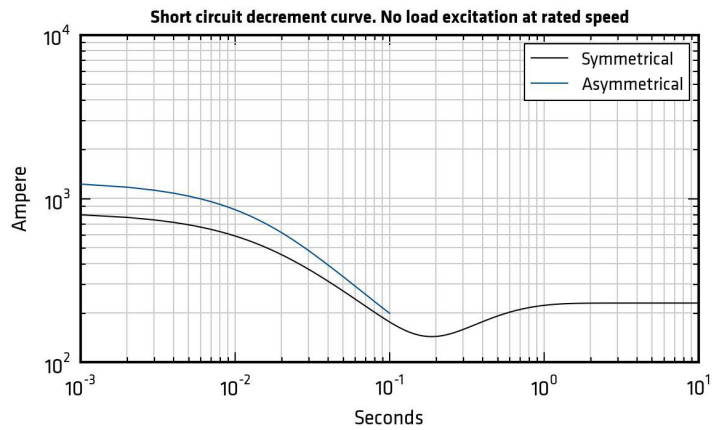

ECP32 2M4 C

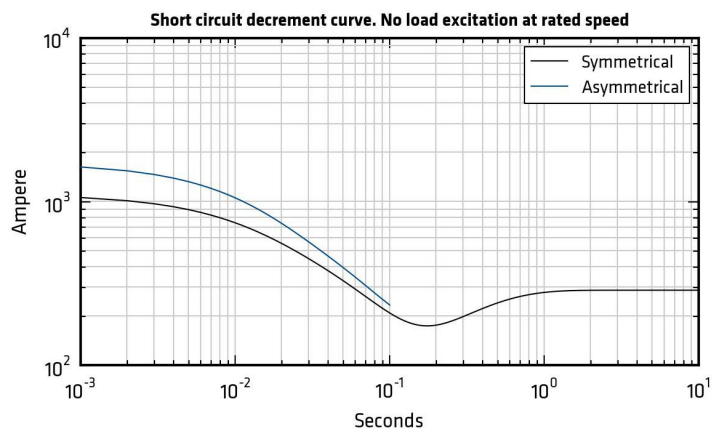

*Please refer to tables at page 6

50Hz Short circuit decrement curves - No load excitation at rated speed

ECP32 1L4 C

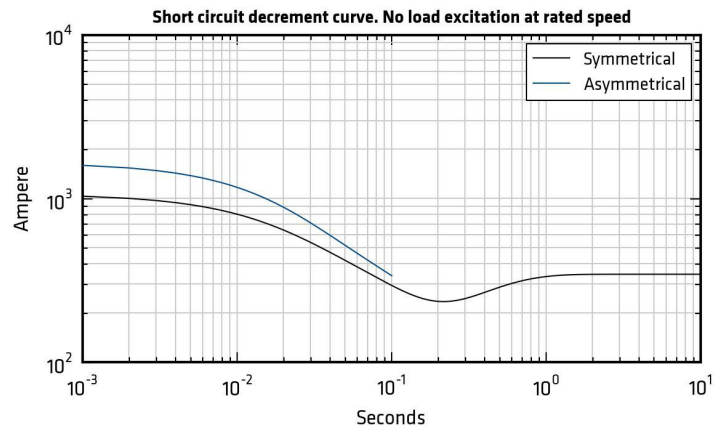

ECP32 2L4 C

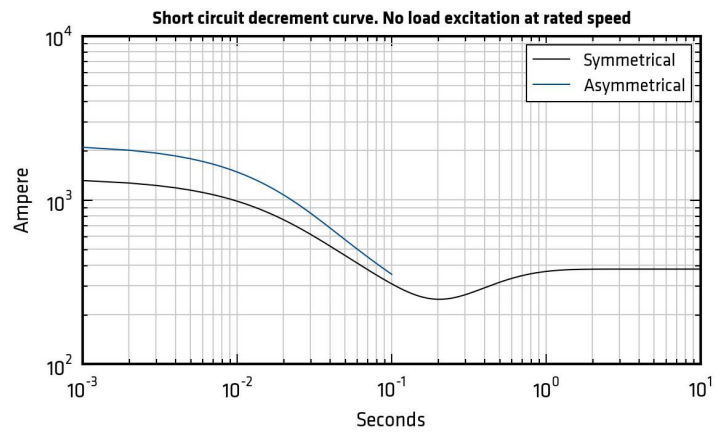

*Please refer to tables at page 6

60Hz Short circuit decrement curves - No load excitation at rated speed

ECP32 1S4 C

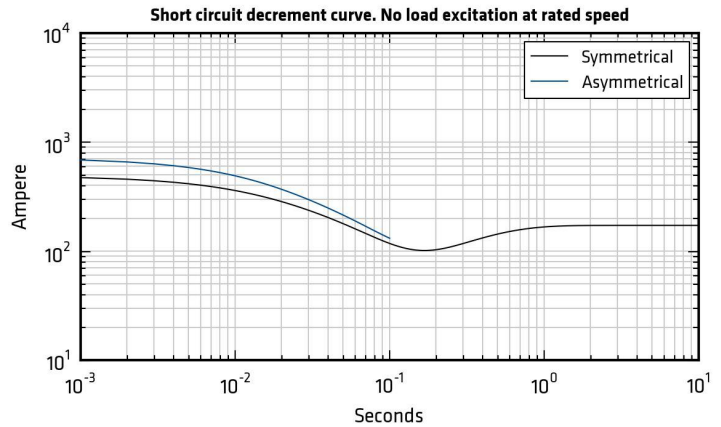

ECP32 2S4 C

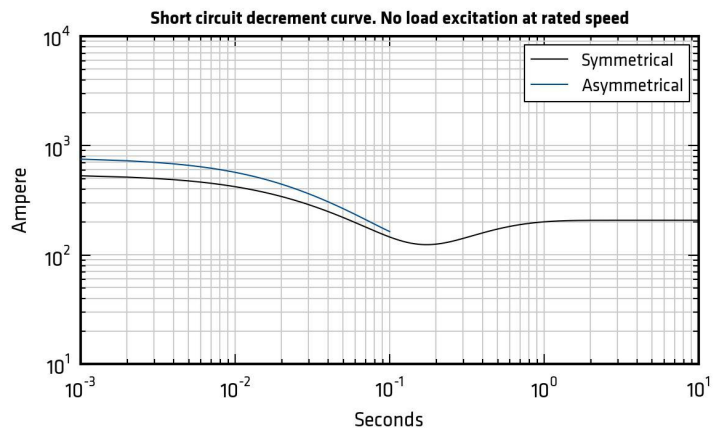

ECP32 1M4 C

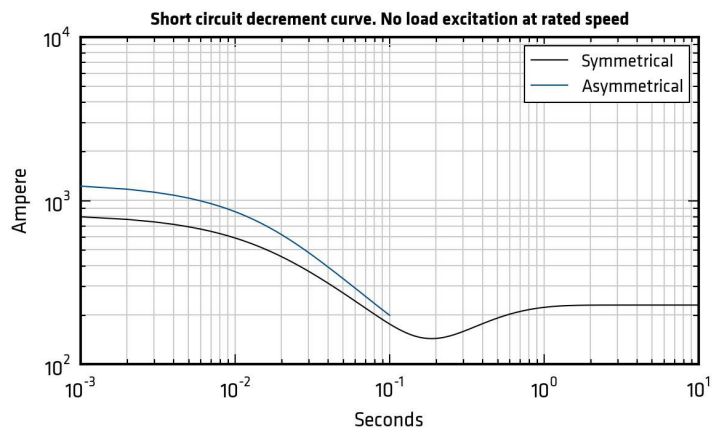

ECP32 2M4 C

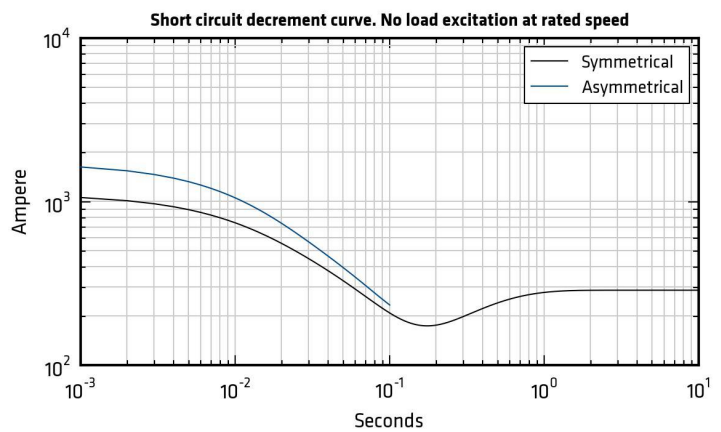

*Please refer to tables at page 6

60Hz Short circuit decrement curves - No load excitation at rated speed

ECP32 1L4 C

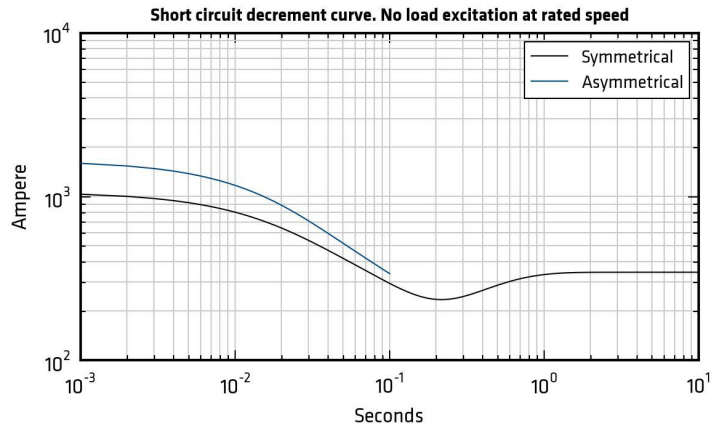

ECP32 2L4 C

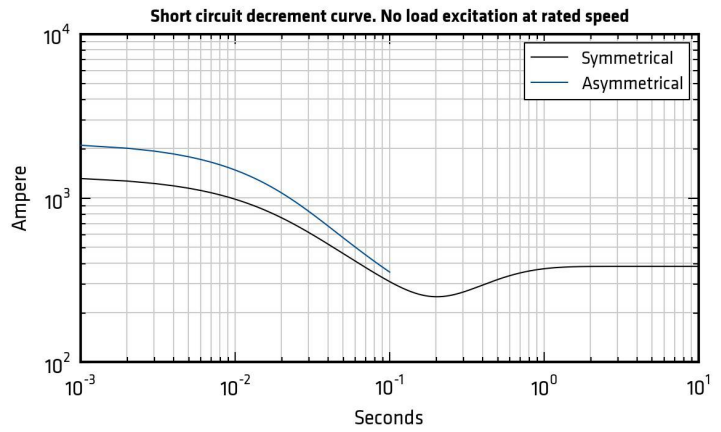

*Please refer to tables at page 6

Additional Characteristics

Data	ECP32 1S4 C		ECP32 2S4 C		ECP32 1M4 C		ECP32 2M4 C		ECP32 1L4 C		ECP32 2L4 C		
	50Hz	60Hz	50Hz	60Hz	50Hz	60Hz	50Hz	60Hz	50Hz	60Hz	50Hz	60Hz	
Damper cage	Aluminium												
Stator Winding Resistance (20°C)	Ω	0,117		0,08		0,059		0,053		0,039		0,035	
Rotor Winding Resistance (20°C)	Ω	1,067		1,159		1,275		1,576		1,668		1,715	
Stator Exciter Resistance (20°C)	Ω	10,6		10,6		10,6		10,6		11,35		11,35	
Rotor Exciter Resistance (20°C)	Ω	0,417		0,417		0,417		0,417		0,442		0,442	
Weight of complete generator	kg	153,0		165,0		186,0		212,0		244,0		252,0	
Unbalanced magnetic pull	kN/mm	4,5		4,5		4,6		4,6		4,9		5,2	
Air flow	m ³ /min	15,7	18,5	15,7	18,5	15,7	18,5	15,7	18,5	15,7	18,5	15,7	18,5
Noise level at 1m/7m	dB(A)	72/58	76/62	72/58	76/62	72/58	76/62	72/58	76/62	72/58	76/62	72/58	76/62

PQ Diagram

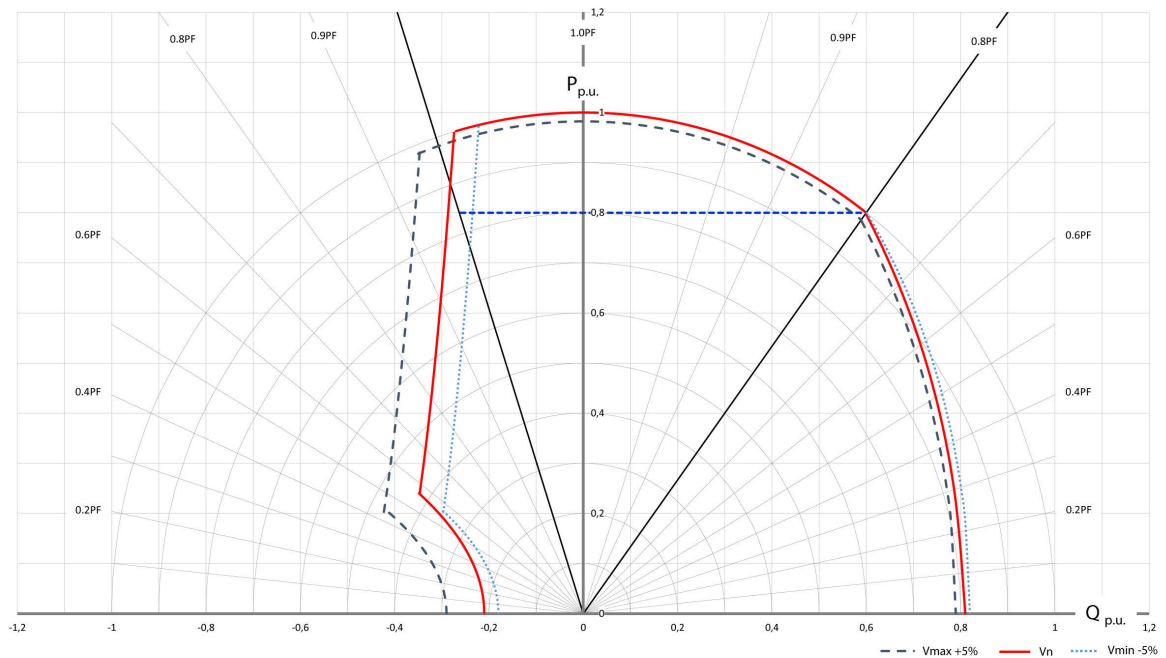

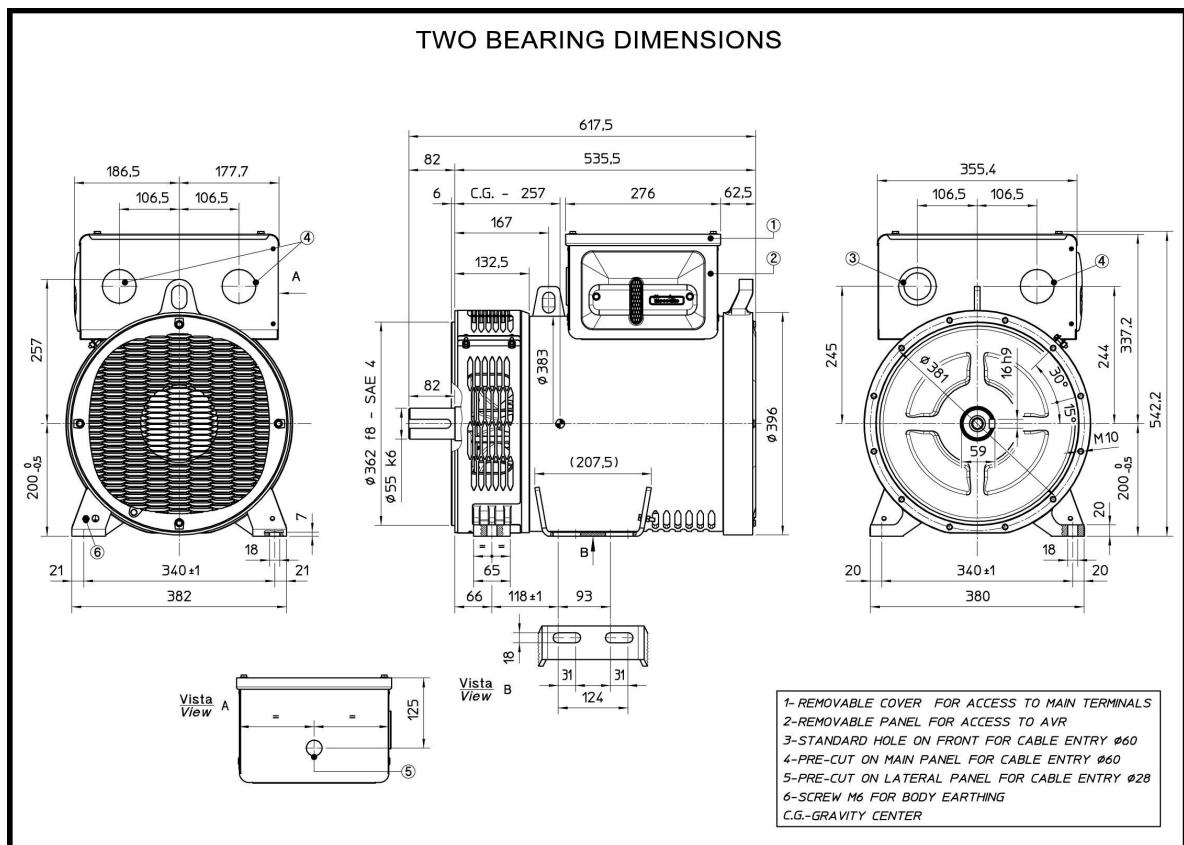
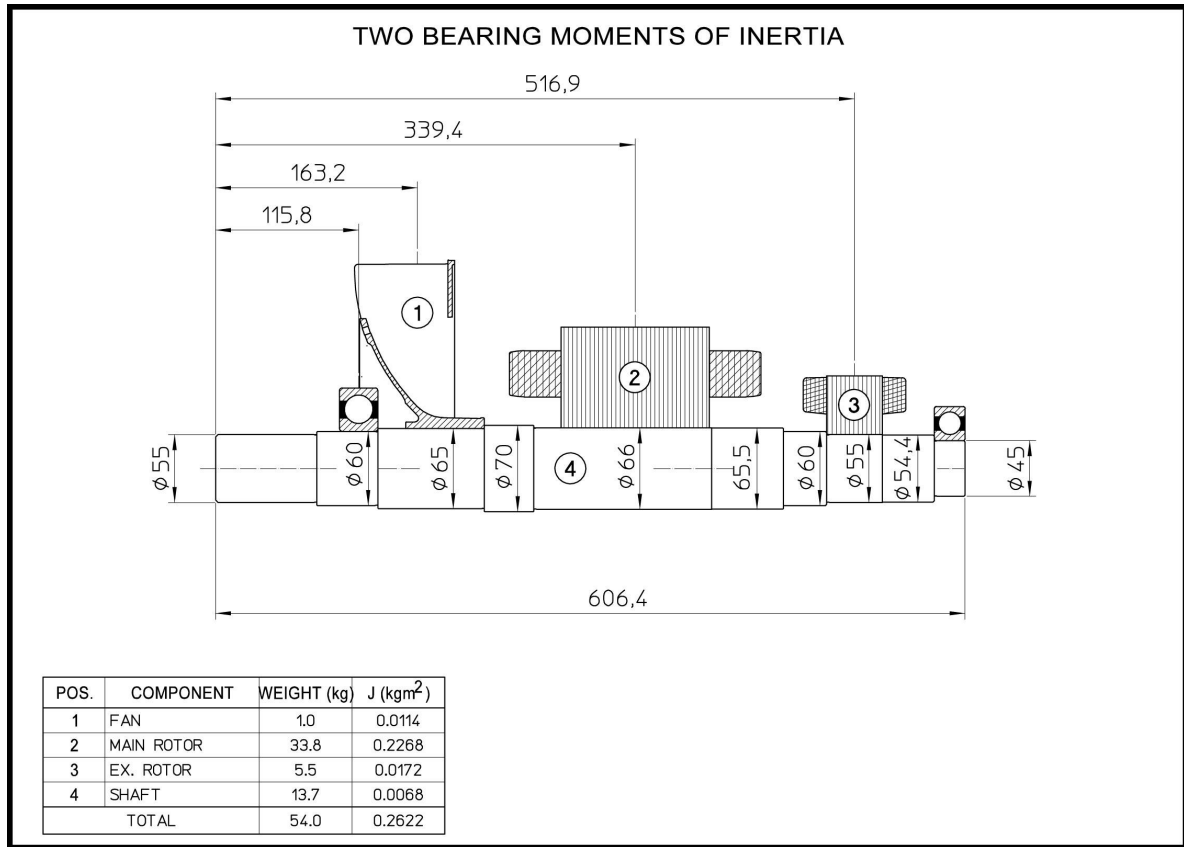

SINGLE BEARING MOMENTS OF INERTIA

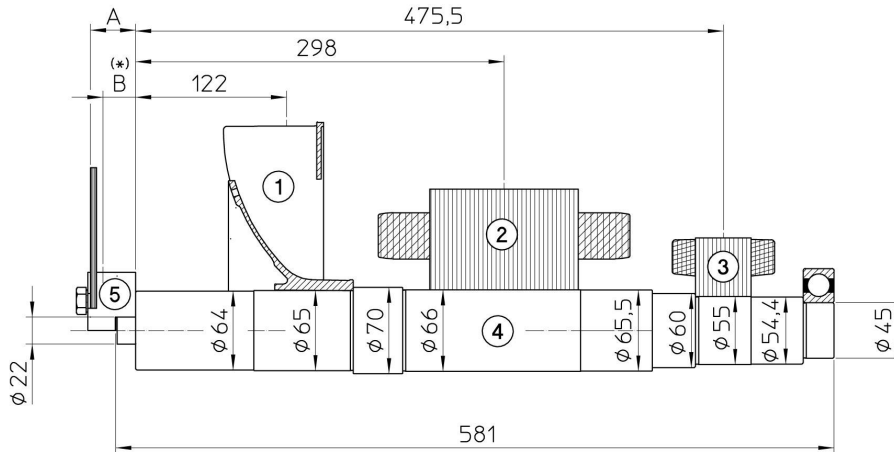

POS.	COMPONENT	WEIGHT (kg)	J (kgm ²)
1	FAN	1.0	0.0114
2	MAIN ROTOR	93.8	0.2268
3	EX. ROTOR	5.5	0.0172
4	SHAFT	13.4	0.0068
TOTAL		53.7	0.2622

SAE N°	A	B	WEIGHT kg	J kgm ²
6 1/2	5	2.2	1.7	0.0084
7 1/2	5	2.2	2.1	0.0130
8	36.6	25.9	4.0	0.0203
10	28.6	21.6	4.5	0.0385
11 1/2	15	11.5	4.5	0.0590

(*) - FLYWHEEL GRAVITY CENTER

SINGLE BEARING DIMENSIONS

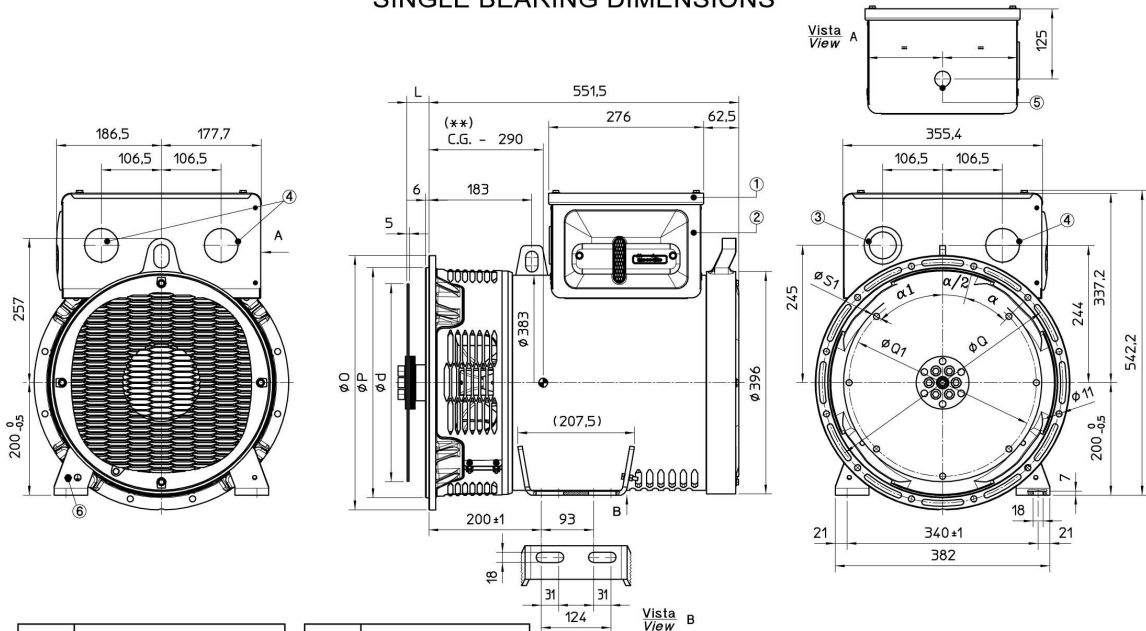

SAE N.	d	L	Q1	S1	α1
6 1/2	215.9	30.2	200	9	60°
7 1/2	241.3	30.2	222.25	9	45°
8	263.52	62	244.47	11	60°
10	314.32	53.8	295.27	11	45°
11 1/2	352.42	39.6	333.37	11	45°

SAE N.	O	P	Q	α
5	356	314.3	333.4	45°
4	402	362	381	30°
3	453	409.6	428.6	30°
2	490	447.7	466.7	30°
1	553	511.2	530.2	30°

- 1- REMOVABLE COVER FOR ACCESS TO MAIN TERMINALS
- 2- REMOVABLE PANEL FOR ACCESS TO AVR
- 3- STANDARD HOLE ON FRONT FOR CABLE ENTRY Ø48
- 4- PRE-CUT ON MAIN PANEL FOR CABLE ENTRY Ø48
- 5- PRE-CUT ON LATERAL PANEL FOR CABLE ENTRY Ø28
- 6- SCREW M6 FOR BODY EARTHING

(**) - GRAVITY CENTER IN CONFIGURATION SAE 3 FLYWHEEL 11 1/2

ECP32 2S4 C

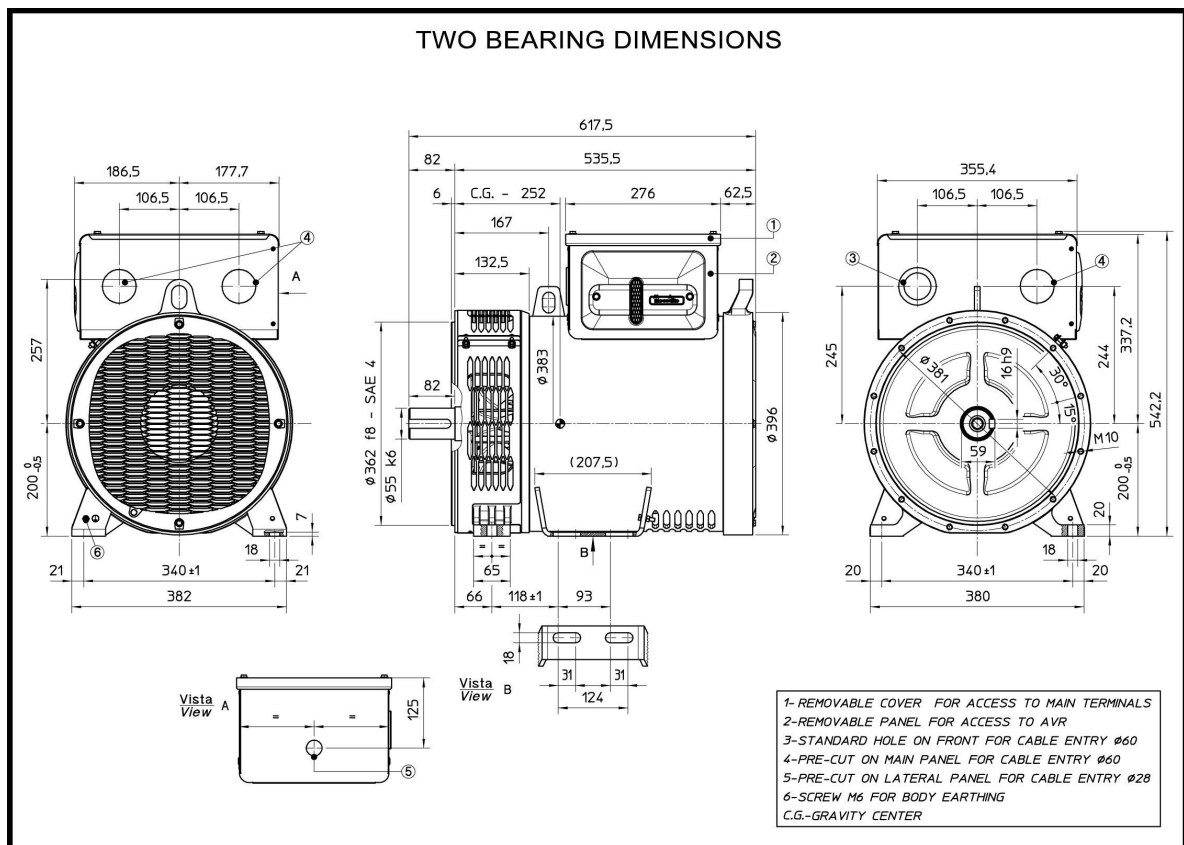
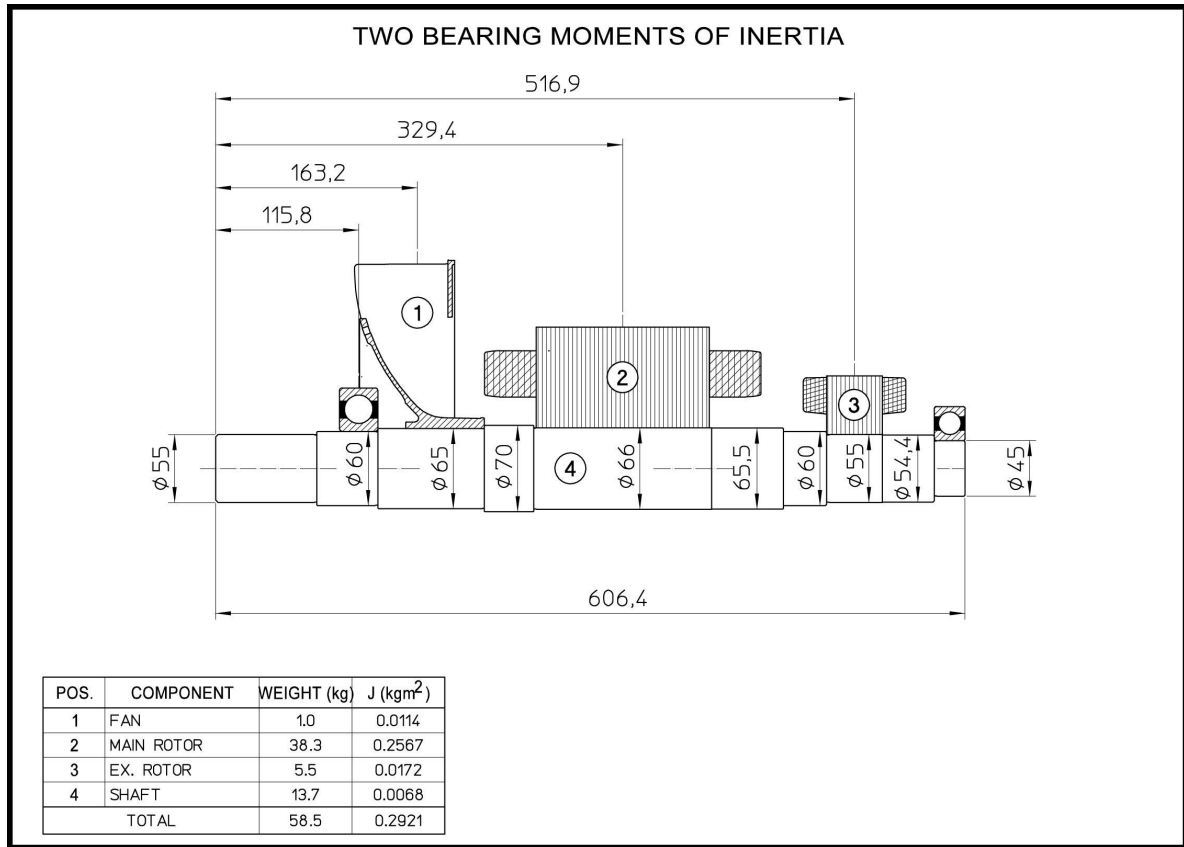

SINGLE BEARING MOMENTS OF INERTIA

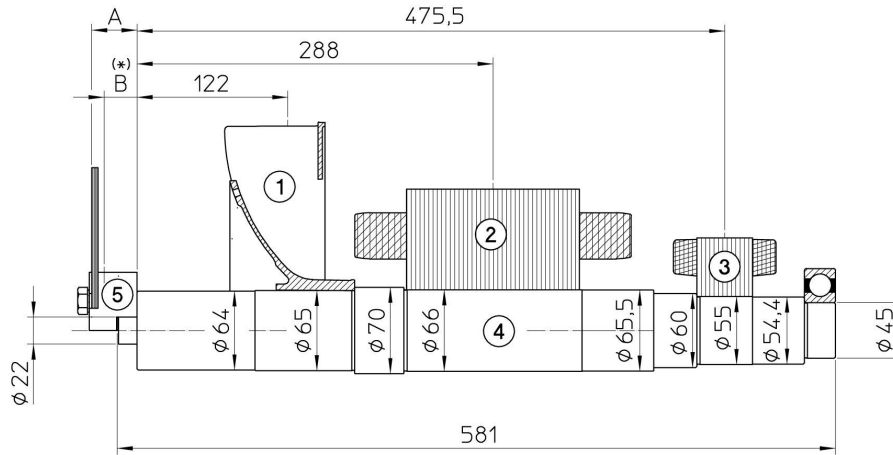

POS.	COMPONENT	WEIGHT (kg)	J (kgm ²)
1	FAN	1.0	0.0114
2	MAIN ROTOR	38.3	0.2567
3	EX. ROTOR	5.5	0.0172
4	SHAFT	13.4	0.0068
TOTAL		58.2	0.2921

SAE N°	A	B	WEIGHT kg	J kgm ²
6 1/2	5	2.2	1.7	0.0084
7 1/2	5	2.2	2.1	0.0130
8	36.6	25.9	4.0	0.0203
10	28.6	21.6	4.5	0.0385
11 1/2	15	11.5	4.5	0.0590

(*) - FLYWHEEL GRAVITY CENTER

SINGLE BEARING DIMENSIONS

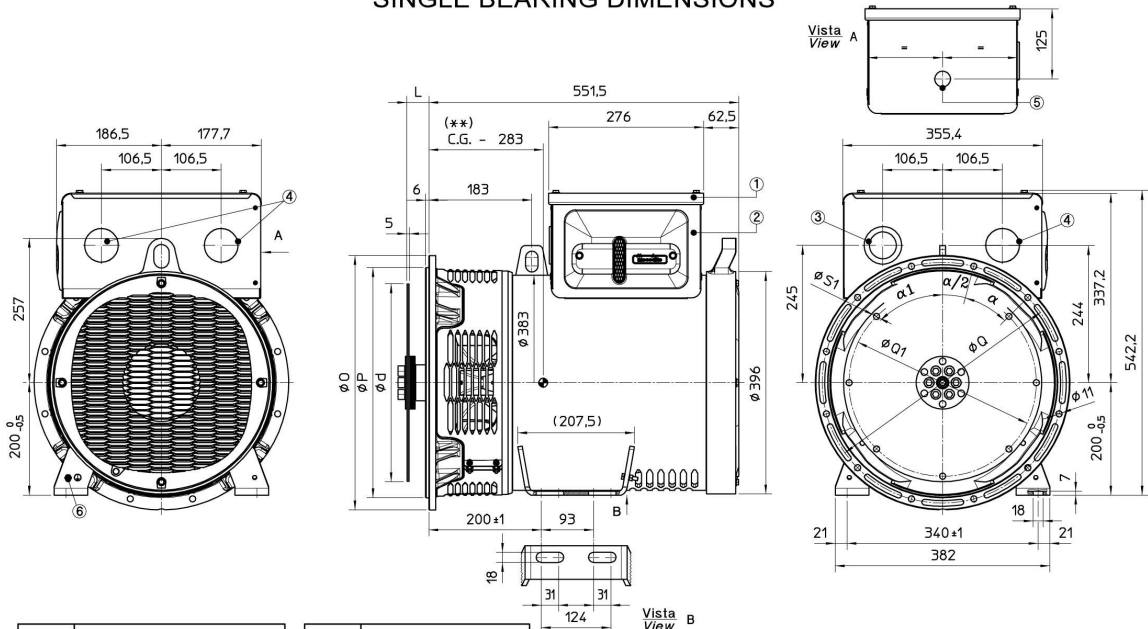

SAE N.	d	L	Q1	S1	α1
6 1/2	215.9	30.2	200	9	60°
7 1/2	241.3	30.2	222.25	9	45°
8	263.52	62	244.47	11	60°
10	314.32	53.8	295.27	11	45°
11 1/2	352.42	39.6	333.37	11	45°

SAE N.	O	P	Q	α
5	356	314.3	333.4	45°
4	402	362	381	30°
3	453	409.6	428.6	30°
2	490	447.7	466.7	30°
1	553	511.2	530.2	30°

- 1- REMOVABLE COVER FOR ACCESS TO MAIN TERMINALS
 - 2- REMOVABLE PANEL FOR ACCESS TO AVR
 - 3- STANDARD HOLE ON FRONT FOR CABLE ENTRY Ø60
 - 4- PRE-CUT ON MAIN PANEL FOR CABLE ENTRY Ø60
 - 5- PRE-CUT ON LATERAL PANEL FOR CABLE ENTRY Ø28
 - 6- SCREW M6 FOR BODY EARTHING
- (**) - GRAVITY CENTER IN CONFIGURATION SAE 3 FLYWHEEL 11 1/2

ECP32 1M4 C

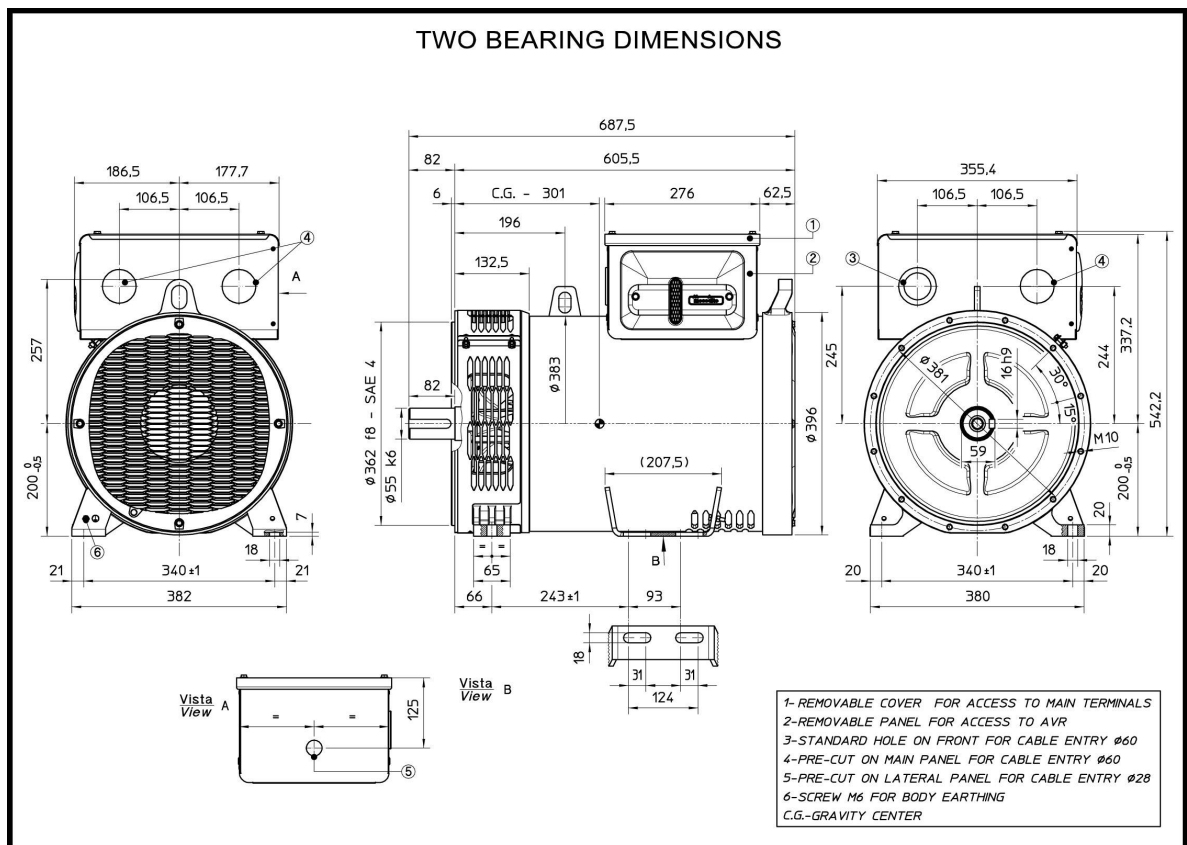
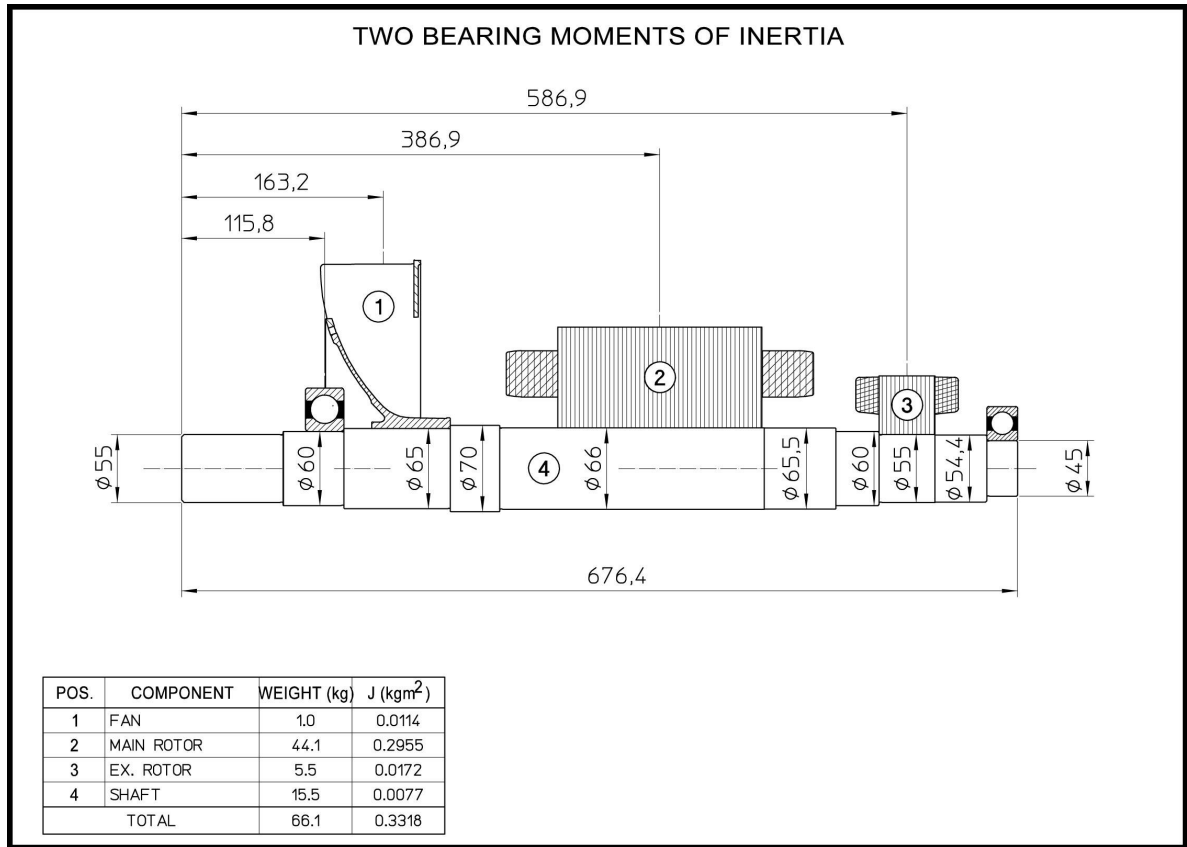

SINGLE BEARING MOMENTS OF INERTIA

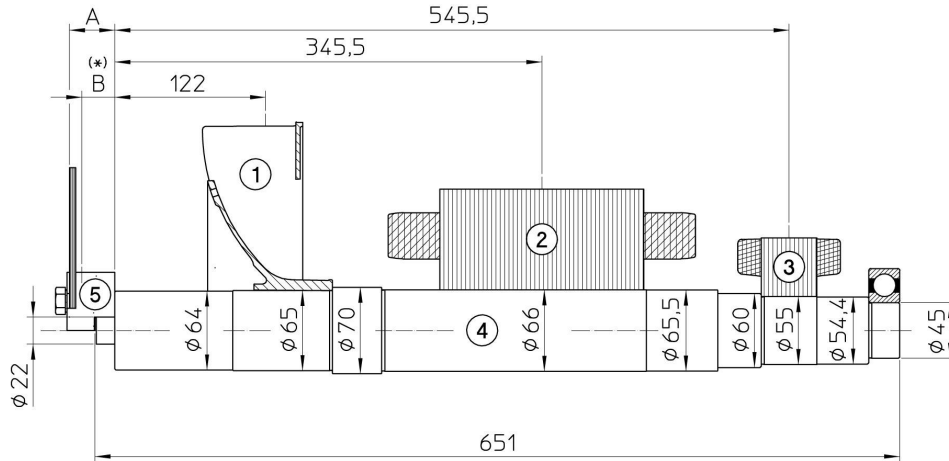

POS.	COMPONENT	WEIGHT (kg)	J (kgm ²)
1	FAN	1.0	0.0114
2	MAIN ROTOR	44.1	0.2955
3	EX. ROTOR	5.5	0.0172
4	SHAFT	15.2	0.0078
TOTAL		65.8	0.3319

SAE N°	A	B	WEIGHT kg	J kgm ²
6 1/2	5	2.2	1.7	0.0084
7 1/2	5	2.2	2.1	0.0130
8	36.6	25.9	4.0	0.0203
10	28.6	21.6	4.5	0.0385
11 1/2	15	11.5	4.5	0.0590

(*) - FLYWHEEL GRAVITY CENTER

SINGLE BEARING DIMENSIONS

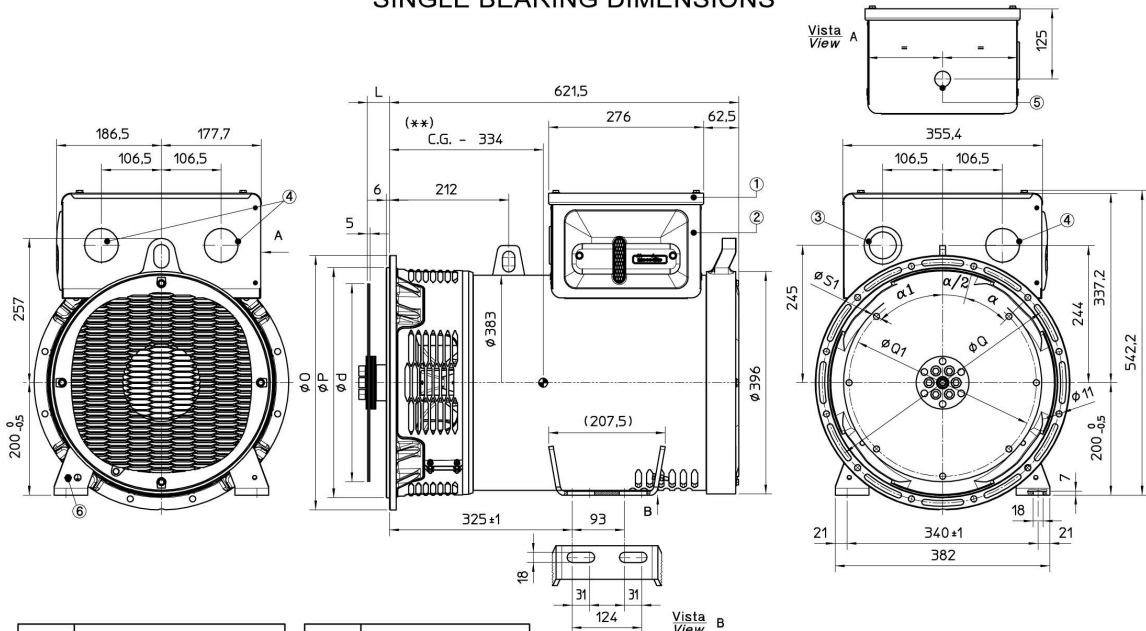

SAE N.	d	L	Q1	S1	α1
6 1/2	215.9	30.2	200	9	60°
7 1/2	241.3	30.2	222.25	9	45°
8	263.52	62	244.47	11	60°
10	314.32	53.8	295.27	11	45°
11 1/2	352.42	39.6	333.37	11	45°

SAE N.	O	P	Q	α
5	356	314.3	333.4	45°
4	402	362	381	30°
3	453	409.6	428.6	30°
2	490	447.7	466.7	30°
1	553	511.2	530.2	30°

- 1- REMOVABLE COVER FOR ACCESS TO MAIN TERMINALS
- 2- REMOVABLE PANEL FOR ACCESS TO AVR
- 3- STANDARD HOLE ON FRONT FOR CABLE ENTRY Ø60
- 4- PRE-CUT ON MAIN PANEL FOR CABLE ENTRY Ø60
- 5- PRE-CUT ON LATERAL PANEL FOR CABLE ENTRY Ø28
- 6- SCREW M6 FOR BODY EARTHING

(**) - GRAVITY CENTER IN CONFIGURATION SAE 3 FLYWHEEL 11 1/2

ECP32 2M4 C

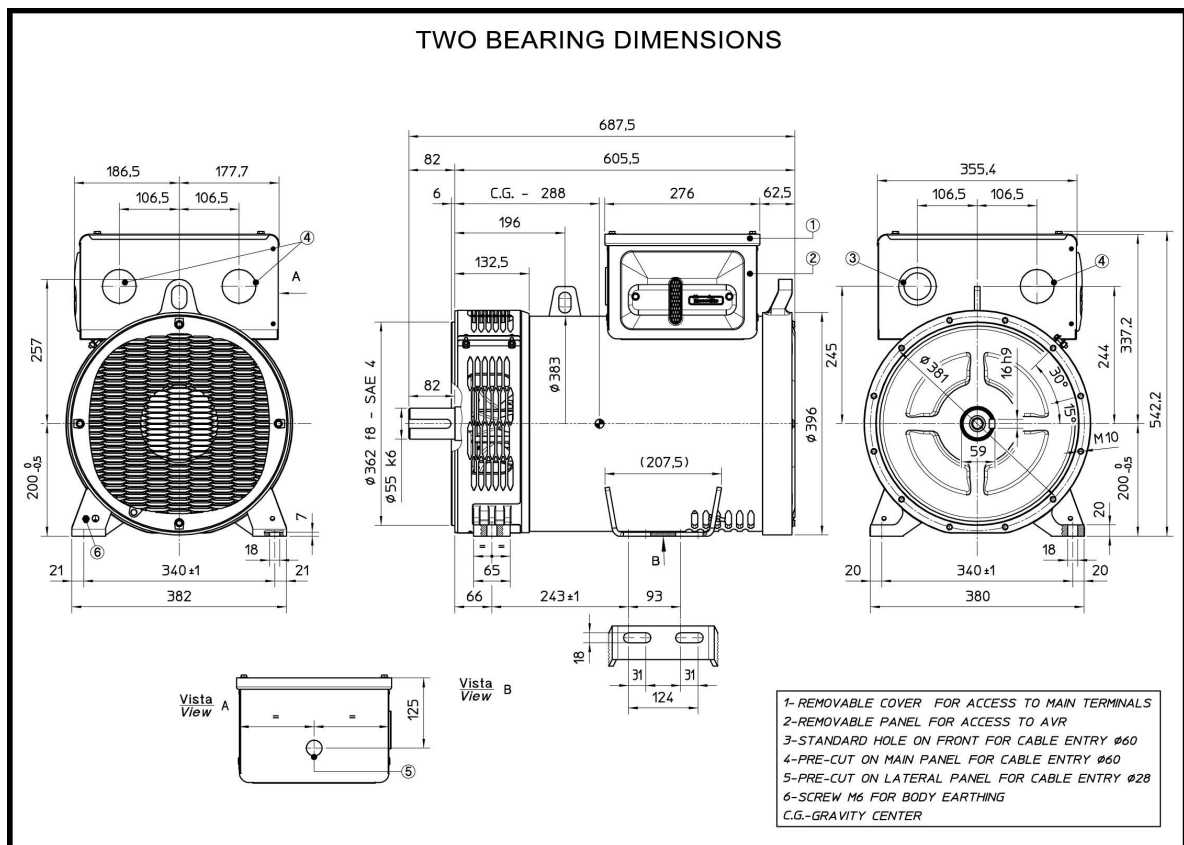
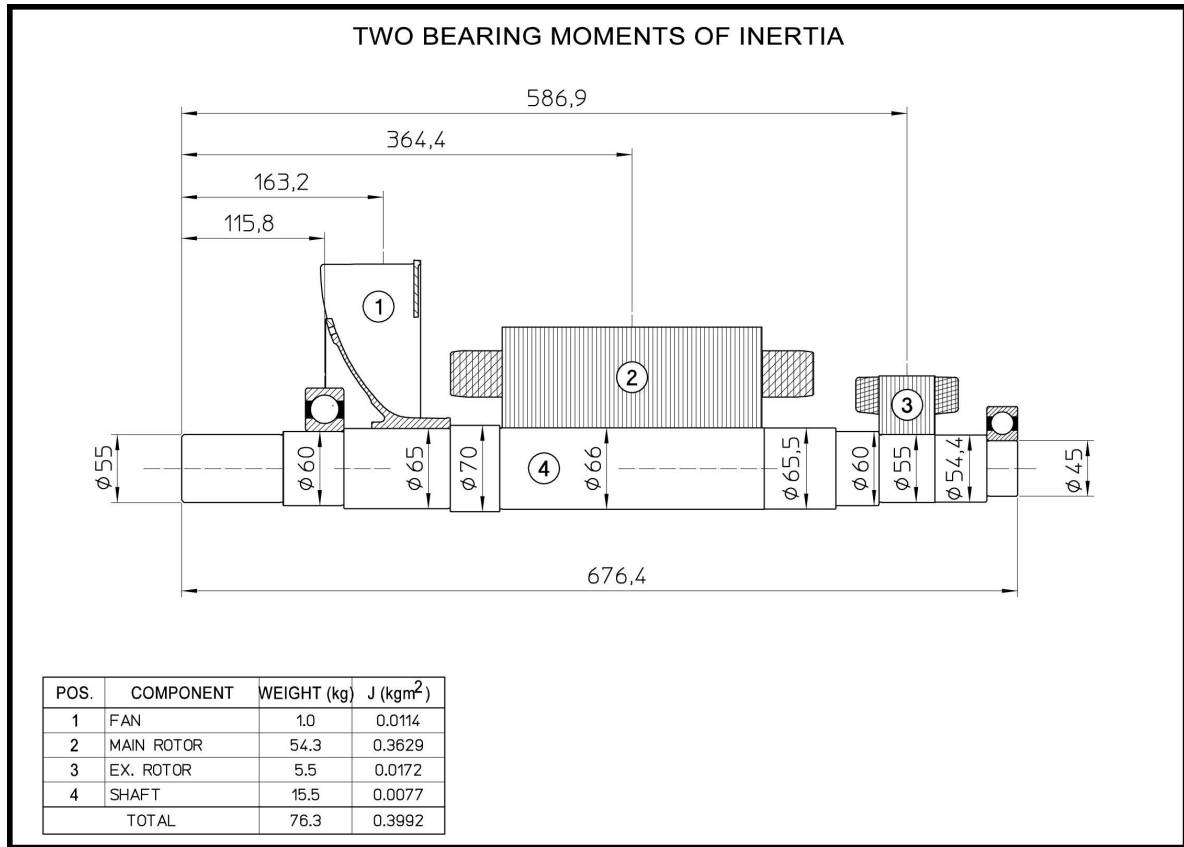

SINGLE BEARING MOMENTS OF INERTIA

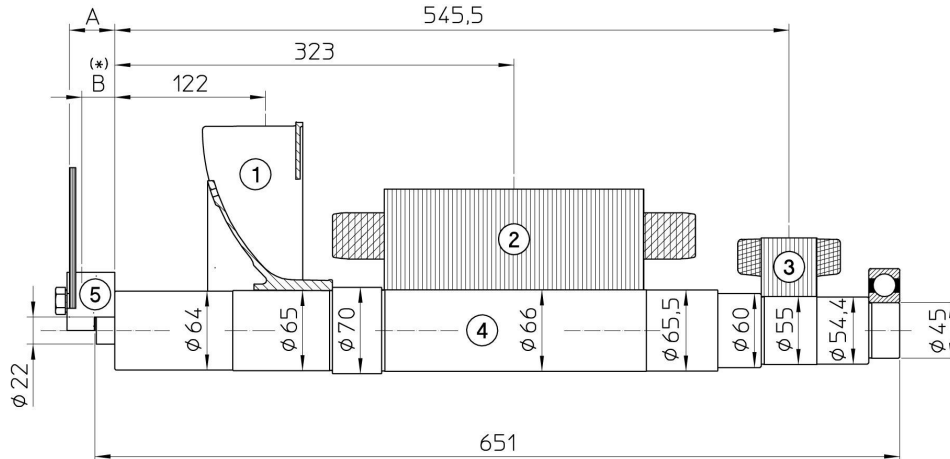

POS.	COMPONENT	WEIGHT (kg)	J (kgm ²)
1	FAN	1.0	0.0114
2	MAIN ROTOR	54.3	0.3629
3	EX. ROTOR	5.5	0.0172
4	SHAFT	15.2	0.0078
TOTAL		76.0	0.3993

SAE N°	A	B	WEIGHT kg	J kgm ²
6 1/2	5	2.2	1.7	0.0084
7 1/2	5	2.2	2.1	0.0130
8	36.6	25.9	4.0	0.0203
10	28.6	21.6	4.5	0.0385
11 1/2	15	11.5	4.5	0.0590

(*) - FLYWHEEL GRAVITY CENTER

SINGLE BEARING DIMENSIONS

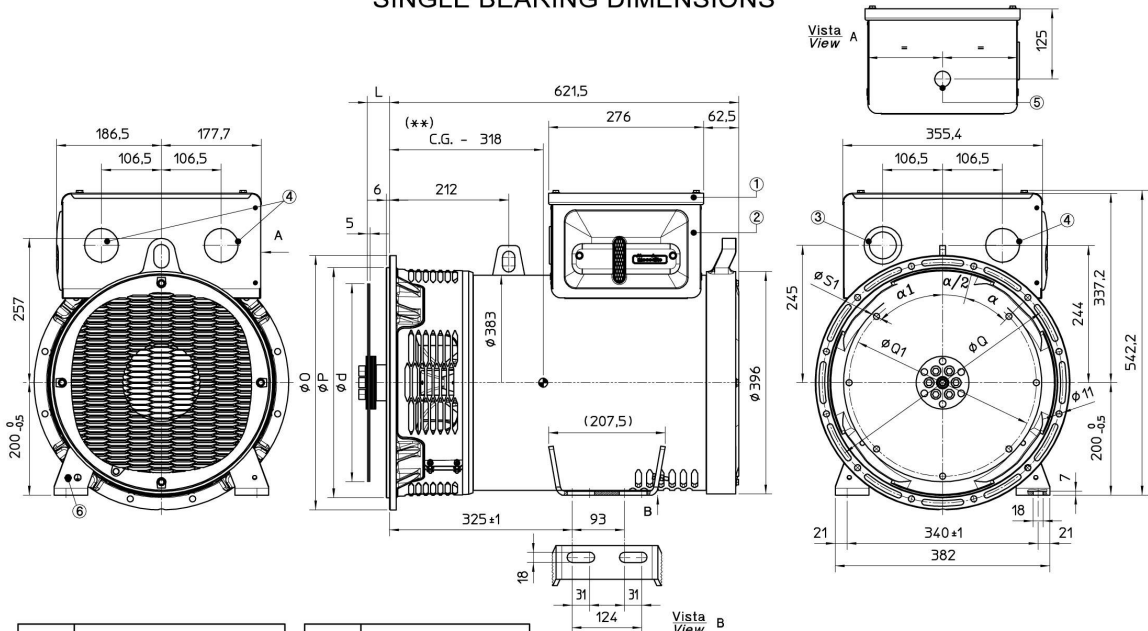

SAE N.	d	L	Q1	S1	α1
6 1/2	215.9	30.2	200	9	60°
7 1/2	241.3	30.2	222.25	9	45°
8	263.52	62	244.47	11	60°
10	314.32	53.8	295.27	11	45°
11 1/2	352.42	39.6	333.37	11	45°

SAE N.	O	P	Q	α
5	356	314.3	333.4	45°
4	402	362	381	30°
3	453	409.6	428.6	30°
2	490	447.7	466.7	30°
1	553	511.2	530.2	30°

- 1- REMOVABLE COVER FOR ACCESS TO MAIN TERMINALS
- 2- REMOVABLE PANEL FOR ACCESS TO AVR
- 3- STANDARD HOLE ON FRONT FOR CABLE ENTRY Ø60
- 4- PRE-CUT ON MAIN PANEL FOR CABLE ENTRY Ø60
- 5- PRE-CUT ON LATERAL PANEL FOR CABLE ENTRY Ø28
- 6- SCREW M6 FOR BODY EARTHING

(**) - GRAVITY CENTER IN CONFIGURATION SAE 3 FLYWHEEL 11 1/2

ECP32 1L4 C

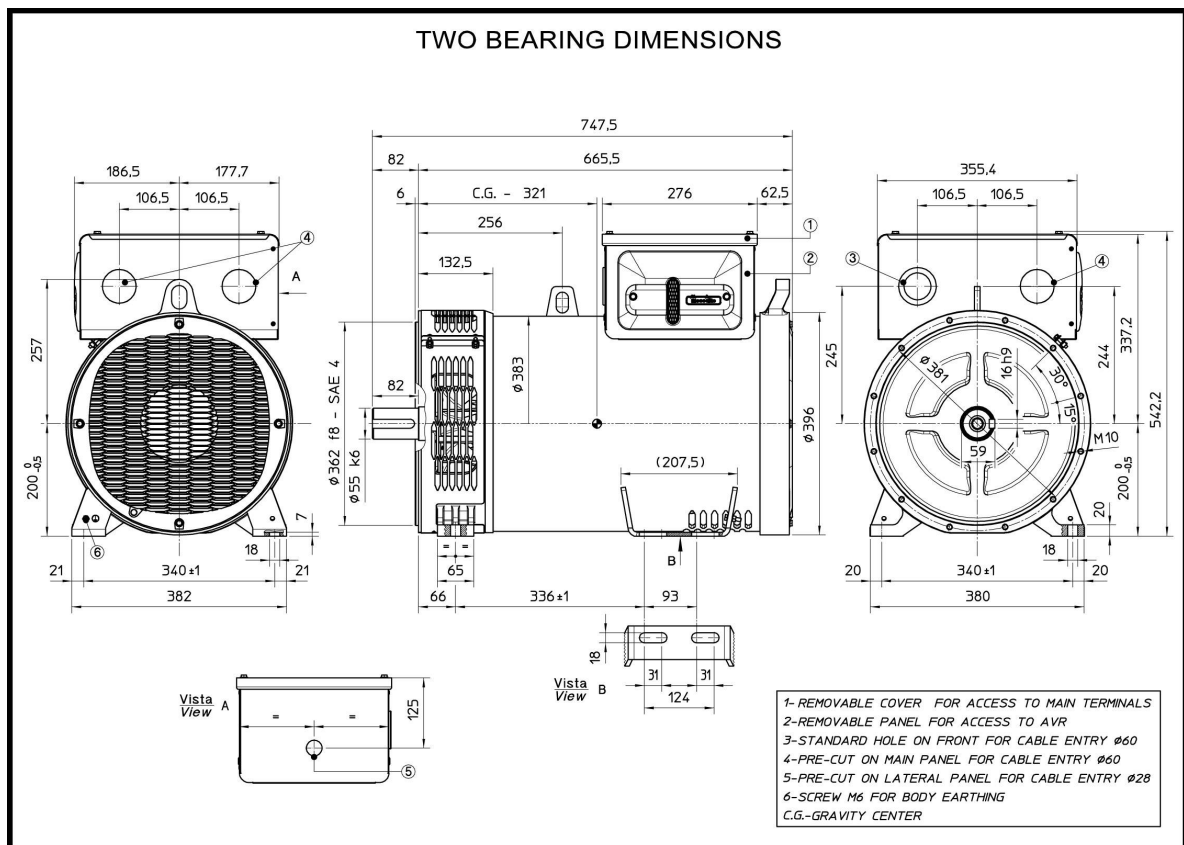
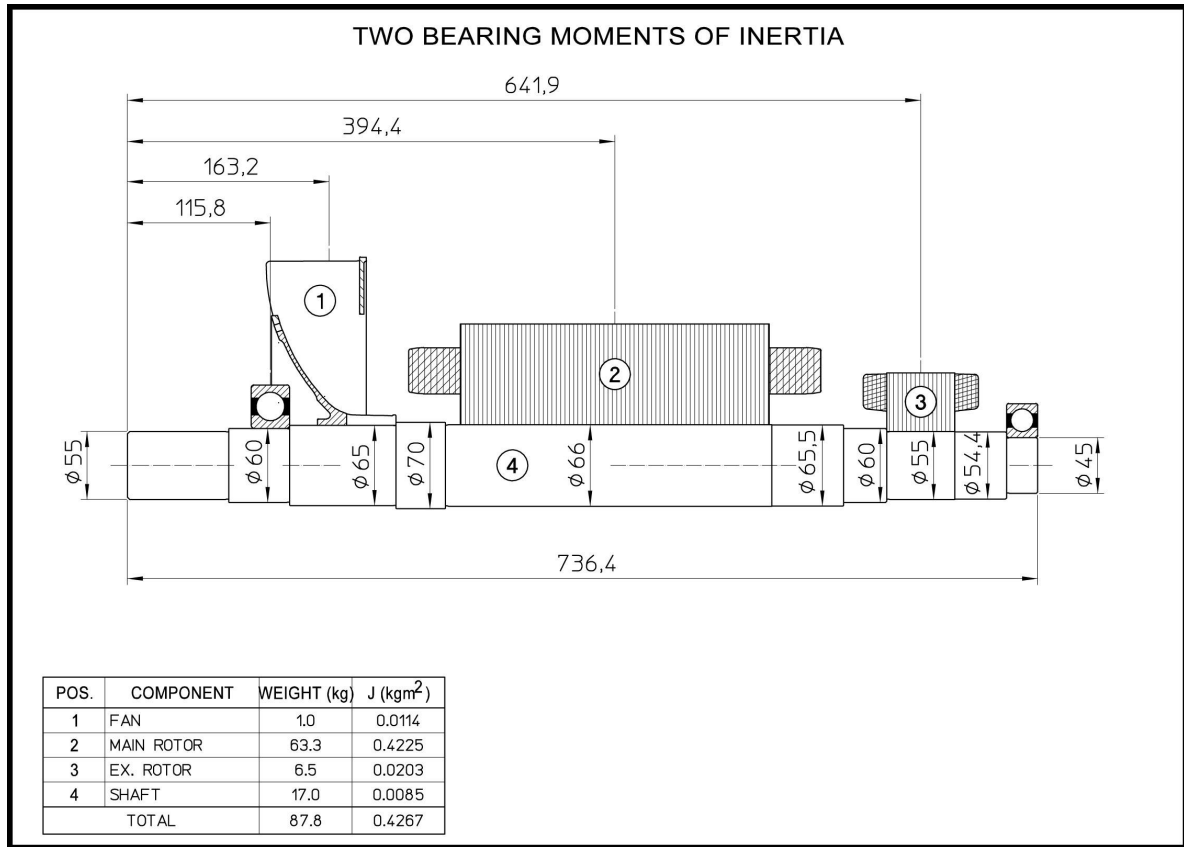

SINGLE BEARING MOMENTS OF INERTIA

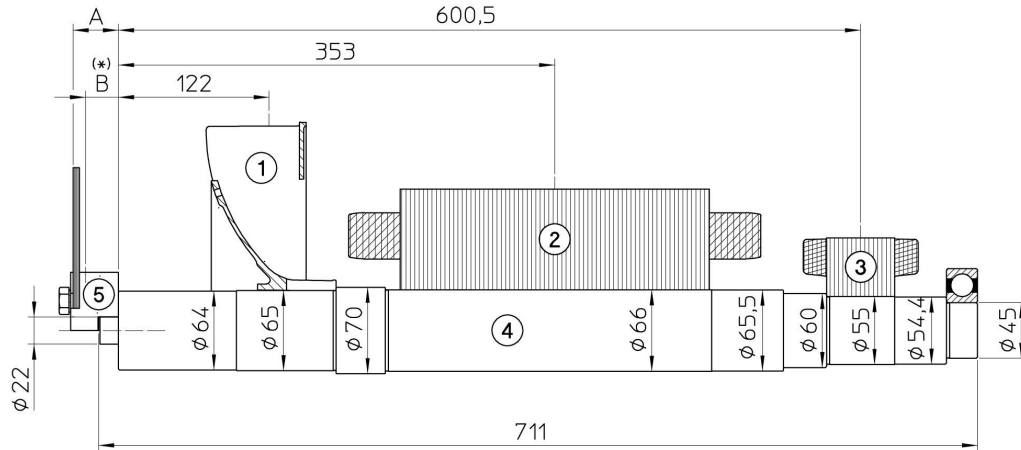

POS.	COMPONENT	WEIGHT (kg)	J (kgm ²)
1	FAN	1.0	0.0114
2	MAIN ROTOR	63.3	0.4225
3	EX. ROTOR	6.5	0.0203
4	SHAFT	16.7	0.0086
TOTAL		87.5	0.4628

SAE N°	A	B	WEIGHT kg	J kgm ²
6 1/2	5	2.2	1.7	0.0084
7 1/2	5	2.2	2.1	0.0130
8	36.6	25.9	4.0	0.0203
10	28.6	21.6	4.5	0.0385
11 1/2	15	11.5	4.5	0.0590

(*) - FLYWHEEL GRAVITY CENTER

SINGLE BEARING DIMENSIONS

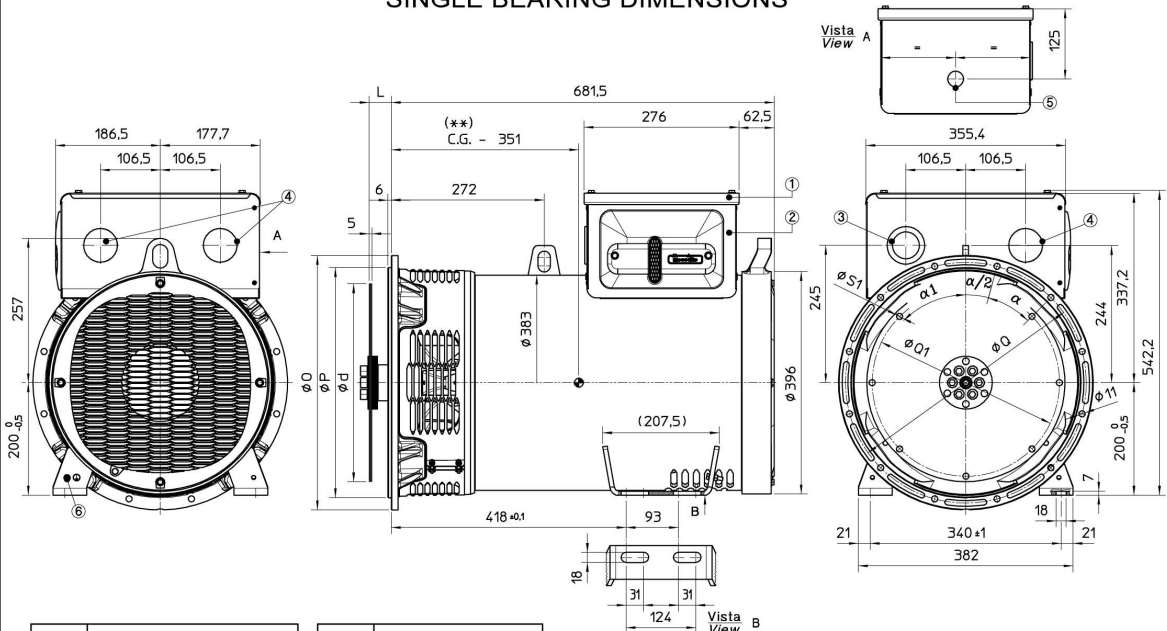

SAE N.	d	L	Q1	S1	$\alpha 1$
6 1/2	215.9	30.2	200	9	60°
7 1/2	241.3	30.2	222.25	9	45°
8	263.52	62	244.47	11	60°
10	314.32	53.8	295.27	11	45°
11 1/2	352.42	39.6	333.37	11	45°

SAE N.	O	P	Q	α
5	356	314.3	333.4	45°
4	402	362	381	30°
3	453	409.6	428.6	30°
2	490	447.7	466.7	30°
1	553	511.2	530.2	30°

- 1- REMOVABLE COVER FOR ACCESS TO MAIN TERMINALS
- 2- REMOVABLE PANEL FOR ACCESS TO AVR
- 3- STANDARD HOLE ON FRONT FOR CABLE ENTRY $\phi 60$
- 4- PRE-CUT ON MAIN PANEL FOR CABLE ENTRY $\phi 60$
- 5- PRE-CUT ON LATERAL PANEL FOR CABLE ENTRY $\phi 28$
- 6- SCREW M6 FOR BODY EARTHING

(**) - GRAVITY CENTER IN CONFIGURATION SAE 3 FLYWHEEL 11 1/2

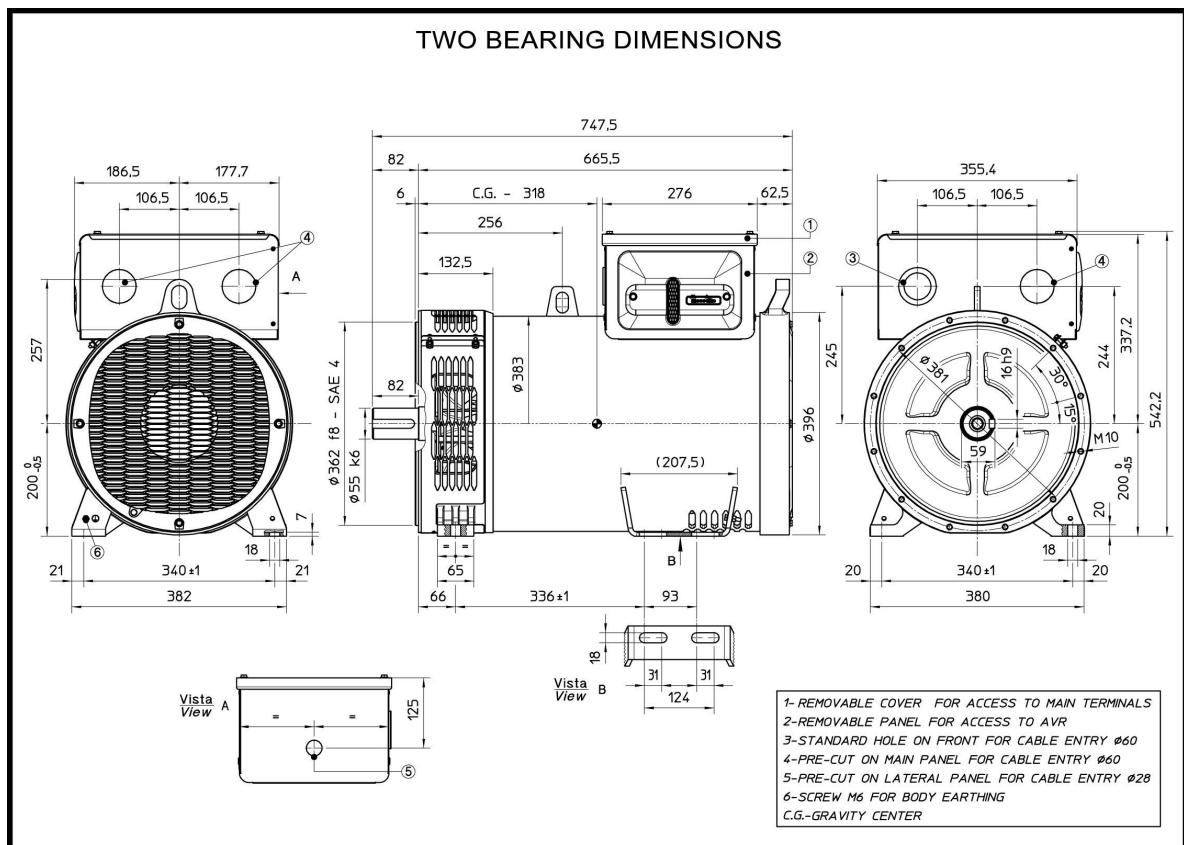
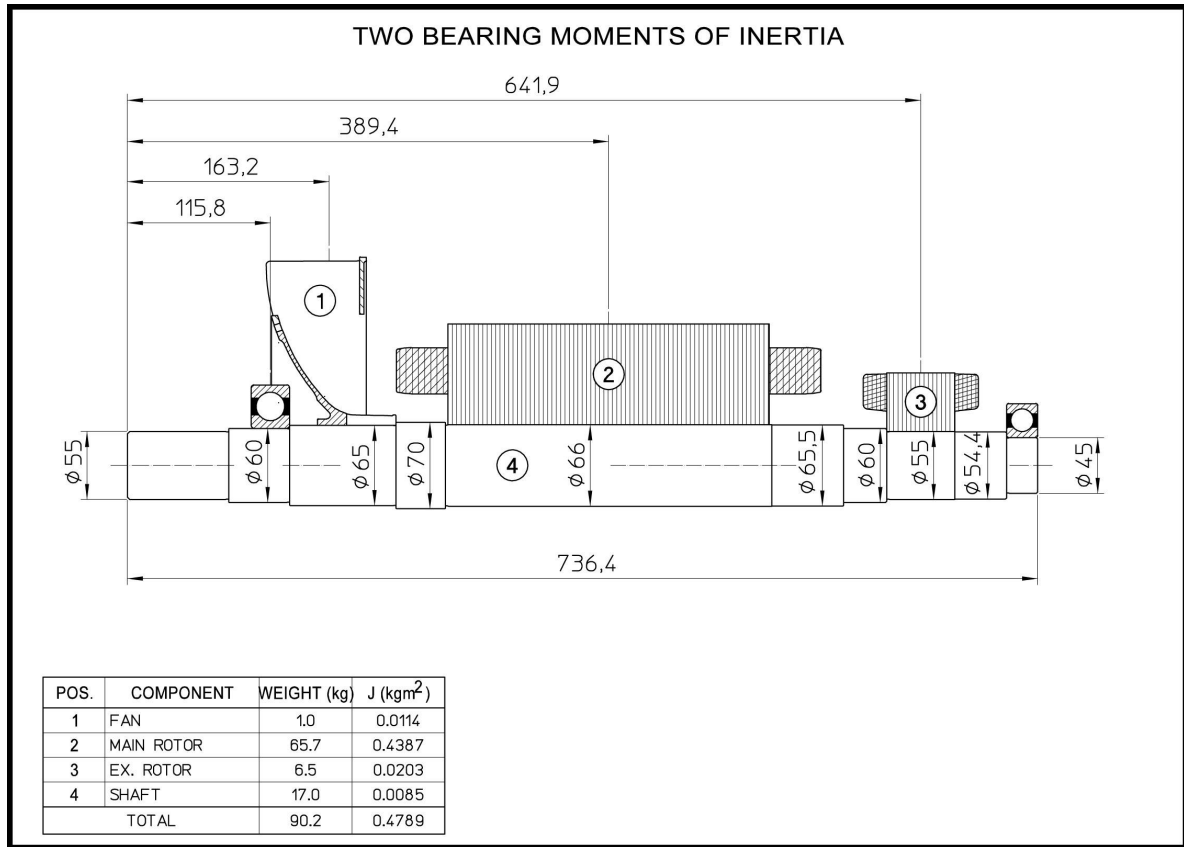

SINGLE BEARING MOMENTS OF INERTIA

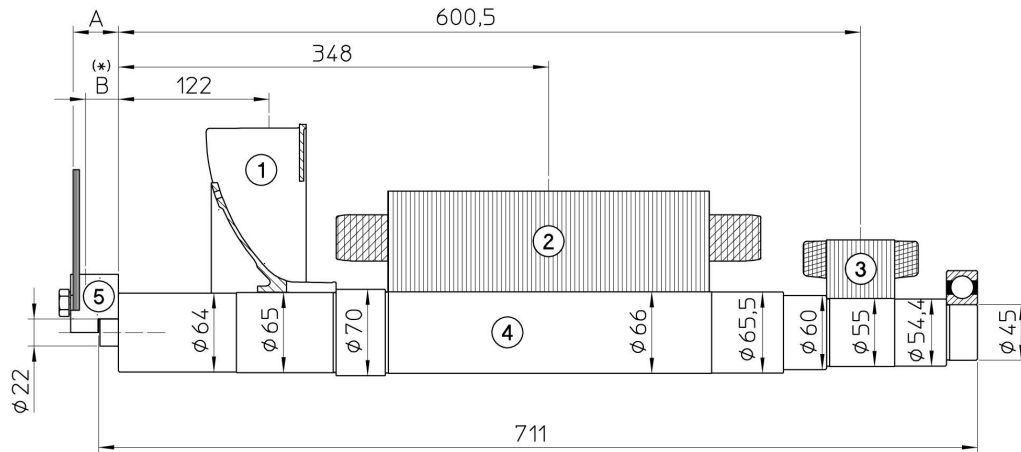

POS.	COMPONENT	WEIGHT (kg)	J (kgm ²)
1	FAN	1.0	0.0114
2	MAIN ROTOR	65.7	0.4387
3	EX. ROTOR	6.5	0.0203
4	SHAFT	16.7	0.0086
TOTAL		89.9	0.4790

SAE N°	A	B	WEIGHT kg	J kgm ²
5	5	2.2	1.7	0.0084
6 1/2	5	2.2	2.1	0.0130
7 1/2	5	2.2	2.1	0.0130
8	36.6	25.9	4.0	0.0203
10	28.6	21.6	4.5	0.0385
11 1/2	15	11.5	4.5	0.0590

(*) - FLYWHEEL GRAVITY CENTER

SINGLE BEARING DIMENSIONS

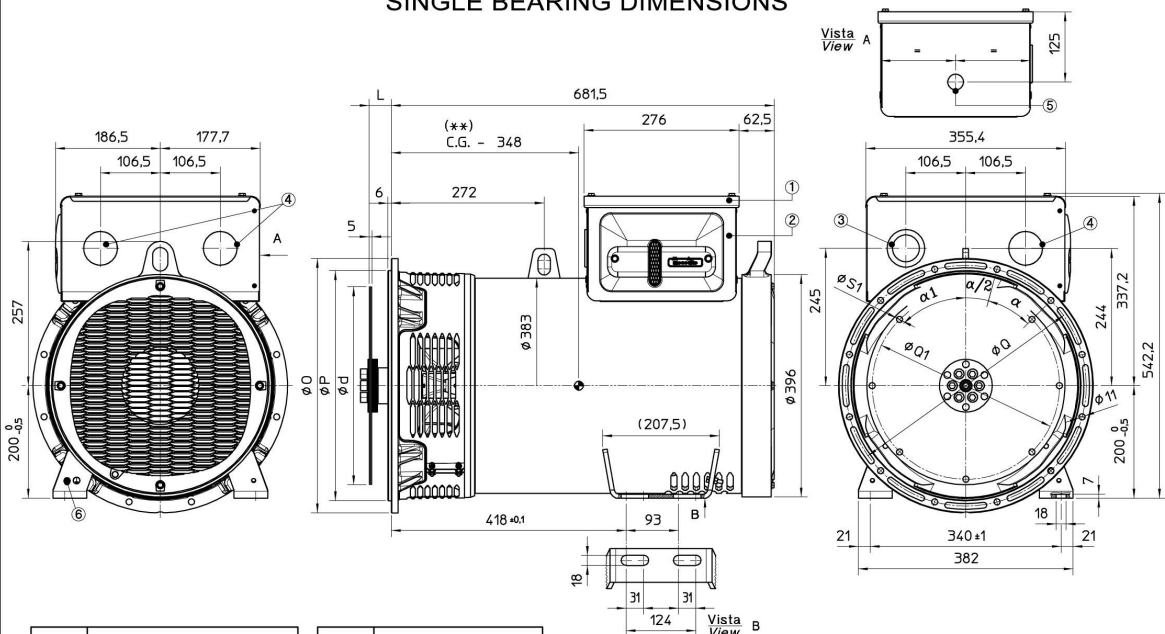

SAE N.	d	L	Q1	S1	α1
6 1/2	215.9	30.2	200	9	60°
7 1/2	241.3	30.2	222.25	9	45°
8	263.52	62	244.47	11	60°
10	314.32	53.8	295.27	11	45°
11 1/2	352.42	39.6	333.37	11	45°

SAE N.	O	P	Q	α
5	356	314.3	333.4	45°
4	402	362	381	30°
3	453	409.6	428.6	30°
2	490	447.7	466.7	30°
1	553	511.2	530.2	30°

- 1- REMOVABLE COVER FOR ACCESS TO MAIN TERMINALS
 - 2- REMOVABLE PANEL FOR ACCESS TO AVR
 - 3- STANDARD HOLE ON FRONT FOR CABLE ENTRY Ø60
 - 4- PRE-CUT ON MAIN PANEL FOR CABLE ENTRY Ø60
 - 5- PRE-CUT ON LATERAL PANEL FOR CABLE ENTRY Ø28
 - 6- SCREW M6 FOR BODY EARTHING
- (**) - GRAVITY CENTER IN CONFIGURATION SAE 3 FLYWHEEL 11 1/2

Notes

Mecc Alte SpA (HQ)

Via Roma
20 - 36051 Creazzo
Vicenza - ITALY
T: +39 0444 396111
F: +39 0444 396166
E: info@meccalte.it
aftersales@meccalte.it

Mecc Alte Portable

Via Roma
20 - 36051 Creazzo
Vicenza - ITALY
T: +39 0444 396111
F: +39 0444 396166
E: info@meccalte.it
aftersales@meccalte.it

Mecc Alte Power Products srl

Via Melaro
Z - 36075 Montecchio
Maggiore (VI) - ITALY
T: +39 0444 1831295
F: +39 0444 1831306
E: info@meccalte.it
aftersales@meccalte.it

Zanardi Alternatori srl

Via Dei Laghi
48/B - 36077 Altavilla
Vicenza - ITALY
T: +39 0444 370799
F: +39 0444 370330
E: info@zanardialternatori.it

United Kingdom

Mecc Alte U.K. LTD
6 Lands' End Way
Oakham
Rutland LE15 6RF
T: +44 (0) 1572 771160
F: +44 (0) 1572 771161
E: info@meccalte.co.uk
aftersales@meccalte.co.uk

Spain

Mecc Alte España S.A.
C/ Rio Taibilla, 2
Polig. Ind. Los Valeros
03178 Benijofar (Alicante)
T: +34 (0) 96 6702152
F: +34 (0) 96 6700103
E: info@meccalte.es
aftersales@meccalte.es

China

Mecc Alte Alternator Haimen LTD
755 Nanghai East Rd
Jiangsu HEDZ 226100 PRC
T: +86 (0) 513 82325758
F: +86 (0) 513 82325768
E: info@meccalte.cn
aftersales@meccalte.cn

India

Mecc Alte India PVT LTD
Plot NO: 1, Sanaswadi
Talegaon
Dhamdhare Road Taluka:
Shirur, District:
Pune - 412208
Maharashtra, India
T: +91 2137 619600
F: +91 2137 619699
E: info@meccalte.in
aftersales@meccalte.in

U.S.A. and Canada

Mecc Alte Inc.
1229 Adams Drive
McHenry, IL, 60051
T: +1 815 344 0530
F: +1 815 344 0535
E: info@meccalte.us
aftersales@meccalte.us

Germany

Mecc Alte Generatoren GmbH
Ensener Weg 21
D-51149 Köln
T: +49 (0) 2203 503810
F: +49 (0) 2203 503796
E: info@meccalte.de
aftersales@meccalte.de

Australia

Mecc Alte Alternators PTY LTD
10 Duncan Road, PO Box 1046
Dry Creek, 5094, South
Australia
T: +61 (0) 8 8349 8422
F: +61 (0) 8 8349 8455
E: info@meccalte.com.au
aftersales@meccalte.com.au

France

Mecc Alte International S.A.
Z.E.La Gagnerie
16330 ST.Amant de Boixe
T: +33 (0) 545 397562
F: +33 (0) 545 398820
E: info@meccalte.fr
aftersales@meccalte.fr

Far East

Mecc Alte (F.E.) PTE LTD
19 Kian Teck Drive
Singapore 628836
T: +65 62 657122
F: +65 62 653991
E: info@meccalte.com.sg
aftersales@meccalte.com.sg



www.meccalte.com